



Paper Type: Original Article

Design and Simulation of a Fuzzy Logic Controller for STATCOM in Power Systems

Seyyedeh Zahra Hosseini^{1*} , Kasra Musavi¹

¹ Department of Electrical Engineering, To.C., Islamic Azad University, Tonekabon, Iran; Shaghayeghosseini@gmail.com; kasramosavi17@gmail.com.

Citation:

Received: 27 August 2024

Revised: 05 October 2024

Accepted: 10 February 2025

Hosseini, S. Z & Musavi, K. (2025). Design and simulation of a Fuzzy logic controller for statcom in power systems. *Intelligence modeling in electromechanical systems*, 2(2), 134-144.

Abstract

This paper presents the design, implementation, and simulation-based evaluation of a Fuzzy Logic Controller (FLC) applied to a Static Synchronous Compensator (STATCOM) for voltage regulation and reactive power compensation in power systems. The proposed FLC replaces the conventional PI controller by employing a two-input (error and change of error) rule-based inference system with triangular membership functions and centroid defuzzification. A comprehensive MATLAB/Simulink model of the STATCOM in the d–q reference frame, including DC-link dynamics, is developed to investigate controller performance under realistic operating scenarios. Two representative test cases—a 20% step increase in reactive load and a 25% increase in coupling inductance—are used to assess transient response, overshoot, settling time, and steady-state accuracy. Comparative results indicate that the FLC significantly improves dynamic behavior: settling time is reduced from 0.45 s (PI) to 0.25 s (FLC), overshoot decreases from 8.2% to 2.5%, and steady-state voltage error improves from 0.015 P.u. to 0.002 p.u. Moreover, the Fuzzy controller exhibits superior robustness to parameter variations. These findings demonstrate that Fuzzy logic-based control provides enhanced transient performance and reliability for STATCOM applications, making it a promising strategy for modern power networks subject to nonlinearities and uncertainties. Key contributions include the tailored FLC rule base, systematic performance comparison with PI control, and demonstration of robustness through parametric perturbation tests.

Keywords: Static synchronous compensator, Fuzzy logic controller, Voltage regulation, Reactive power compensation, Robustness.

1 | Introduction

The modern power system is increasingly characterized by high penetration of renewable energy sources, varying load demands, and dynamic grid conditions that significantly affect voltage stability and power quality [1]. In such environments, maintaining an adequate level of reactive power compensation and voltage

 Corresponding Author: alibahadori1374@gmail.com

 <https://doi.org/10.48314/imes.vi.32>

 Licensee System Analytics. This article is an open access article distributed under the terms and conditions of the Creative Commons Attribution (CC BY) license (<http://creativecommons.org/licenses/by/4.0>).

regulation has become a major operational challenge [2]. Flexible AC Transmission System (FACTS) devices have emerged as a viable solution to enhance the controllability, reliability, and efficiency of power transmission networks [3]. Among various FACTS controllers, the Static Synchronous Compensator (STATCOM) has gained widespread attention due to its fast response, superior reactive power support, and capability to regulate voltage under both steady-state and transient conditions [4].

A STATCOM operates as a shunt-connected Voltage Source Converter (VSC) that injects or absorbs reactive current to maintain the system voltage at a desired reference value [5]. Its performance, however, depends greatly on the effectiveness of the control strategy employed. Conventional control schemes, particularly the Proportional–Integral (PI) controller, are simple to implement and have been widely used in industrial applications [6]. Nonetheless, PI controllers are inherently linear and rely on fixed gain parameters, which limits their effectiveness when dealing with nonlinearities, parameter variations, and time-varying operating conditions commonly present in power systems [7]. As a result, under sudden load changes or grid disturbances, PI-based controllers may exhibit slow dynamic response, large overshoot, and reduced robustness [8].

To address these shortcomings, intelligent control techniques have been introduced into power system applications. Among them, Fuzzy logic control has proven to be an effective and robust alternative for nonlinear and uncertain systems [9]. Unlike conventional controllers, a Fuzzy Logic Controller (FLC) does not require an accurate mathematical model of the system. Instead, it uses linguistic rules based on expert knowledge to map input errors and their rate of change to appropriate control actions [10]. This ability allows FLCs to handle complex and uncertain dynamics effectively, providing adaptive performance under varying operating conditions [11]. Previous studies, such as those by Mak et al. [12] and Shen et al. [13], have demonstrated that Fuzzy-based STATCOM controllers can achieve faster voltage recovery and smaller overshoot compared to traditional PI controllers [14].

Despite these advancements, further investigation is required to systematically analyze the transient performance, steady-state accuracy, and robustness of Fuzzy-based STATCOM control under diverse system disturbances and parameter variations [9]. Moreover, few comparative studies have provided detailed quantitative performance indices that clearly highlight the superiority of Fuzzy logic control over conventional techniques [15].

This paper aims to design and simulate a FLC for a STATCOM and to compare its performance with that of a conventional PI controller under different operating scenarios [6]. The proposed FLC is developed using two input variables error and change in error and a rule base composed of triangular membership functions to ensure smooth control action [16]. The controllers are tested in MATLAB/Simulink under realistic power system conditions, including sudden load changes and parameter perturbations [17]. The simulation results are analyzed in terms of settling time, overshoot, steady-state error, and robustness. The outcomes clearly demonstrate that the proposed Fuzzy controller enhances the transient response, reduces overshoot, and provides more stable voltage regulation than the PI controller, thereby offering a practical and efficient solution for real-time STATCOM control in modern power systems [18].

2 | System Modeling

A STATCOM is a shunt-connected reactive power compensating device based on a VSC [3]. It maintains the desired voltage at the Point of Common Coupling (PCC) by injecting or absorbing reactive current. The general configuration of a STATCOM consists of a three-phase VSC, a DC-link capacitor, a coupling transformer, and an AC source representing the power system [4]. A simplified single-line diagram of the STATCOM connected to the grid is shown in *Fig. 1*.

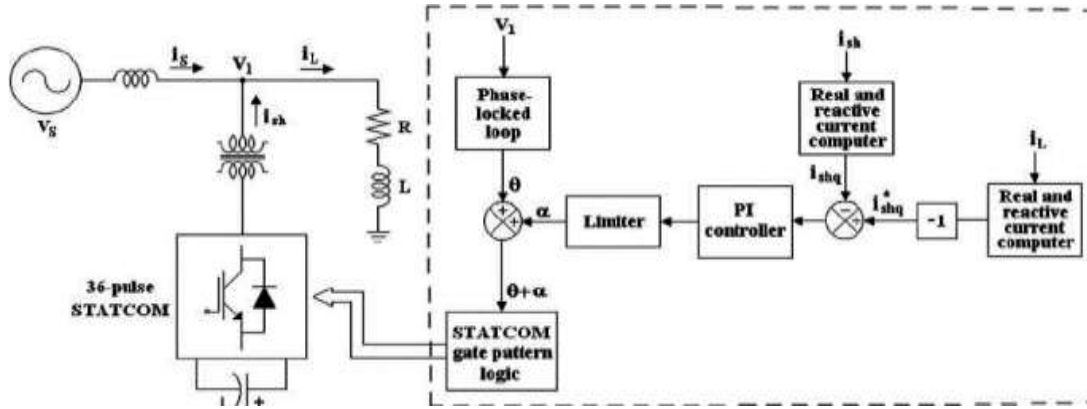

Fig. 1. diagram of the STATCOM.

The VSC generates a controllable AC voltage from a DC input by using Pulse Width Modulation (PWM) techniques. By adjusting the phase angle and magnitude of the converter output voltage with respect to the grid voltage, the STATCOM can control the reactive current flow. When the converter output voltage is greater than the system voltage, the STATCOM supplies reactive power conversely, when it is lower, the STATCOM absorbs reactive power.

2.1 | Mathematical Model in d–q Reference Frame

To simplify the analysis and controller design, the three-phase system equations are transformed into a rotating d–q reference frame synchronized with the grid voltage vector using Park's transformation [7]. The dynamic equations of the STATCOM in the d–q frame are expressed as:

$$V_d = R i_d + L \frac{di_d}{dt} - \omega L i_q + V_{sd}$$

$$V_q = R i_q + L \frac{di_q}{dt} + \omega L i_d + V_{sq}$$

where

V_d, V_q : output voltages of the VSC in the d and q axes

i_d, i_q : current components in the d and q axes

V_{sd}, V_{sq} : system voltages in the d and q axes

R, L : resistance and inductance of the coupling transformer

ω : Angular frequency of the grid

The d-axis current i_d primarily governs the active power exchange between the VSC and the grid, while the q-axis current i_q controls the reactive power flow. Consequently, the STATCOM's control objectives are to regulate the AC bus voltage by adjusting i_q and to maintain the DC-link voltage V_{dc} at its reference value through i_d regulation

The d-axis component i_d primarily controls the active power exchange between the converter and the grid, while the q-axis component i_q controls the reactive power. Thus, the control objective of the STATCOM is to regulate the AC bus voltage by appropriately adjusting i_q , while maintaining the DC-link voltage V_{dc} at its reference level through i_d regulation [9–11].

2.2 | DC-Link Voltage Dynamics

The DC-link capacitor provides the required energy storage and maintains a stable DC voltage for the converter operation. Its dynamics are represented by:

$$C_{dc} \frac{dv_{dc}}{dt} = i_{dc} - \frac{V_{dc}}{R_{dc}},$$

where

C_{dc} : the DC-link capacitance.

i_{dc} : the DC-side current.

R_{dc} : represents equivalent losses in the DC circuit.

The instantaneous power balance between the AC and DC sides can be expressed as:

$$V_d i_d + V_q i_q = V_{dc} i_{dc}.$$

This relationship ensures that the DC-link voltage is maintained at the desired value by controlling the active power exchange through i_d . Deviations in V_{dc} indicate power imbalance, which must be corrected by the controller to ensure continuous and stable operation [15].

2.3 | Control Objectives

The STATCOM control system has two main objectives:

- I. Ac voltage regulation: maintain the bus voltage V_s at its reference value under varying load and system conditions by controlling the reactive current component i_q .
- II. Dc-link voltage control: keep V_{dc} constant at the reference level to provide adequate reactive power capability by adjusting the active current component i_d .

These dual objectives are achieved using an inner current control loop and an outer voltage regulation loop. The subsequent section presents the design of two controllers conventional PI and Fuzzy logic-based for achieving these objectives efficiently [11, 14–16].

3 | Controller Design

The overall control objective of the STATCOM is to regulate the AC bus voltage by controlling the reactive current component i_q and to maintain the DC-link voltage V_{dc} at its reference level. The control system is implemented through two cascaded loops: an outer voltage control loop and an inner current control loop. The outer loop generates the reference current commands based on voltage deviations, while the inner loop ensures that the converter currents track these references accurately. Two control strategies are considered for comparison: a conventional Proportional–Integral (PI) controller and a FLC.

3.1 | Conventional PI Controller

The PI controller is widely used in industrial applications due to its simple structure and ease of implementation. It provides satisfactory performance when the system operates around a nominal operating point. The control law of the PI controller is expressed as:

$$u(t) = K_p e(t) + K_i \int e(t) dt,$$

where $e(t)$ represents the control error (difference between the reference and measured variable), K_p is the proportional gain, and K_i is the integral gain [17].

In the STATCOM application, the PI controller regulates both the AC voltage and the DC-link voltage. The proportional term provides an immediate corrective action proportional to the magnitude of the error, while the integral term eliminates steady-state error by accumulating the error over time. However, the PI controller assumes linearity and constant system parameters, which limits its effectiveness in nonlinear and

time-varying systems. Under sudden load changes or disturbances, the PI controller may exhibit overshoot, longer settling time, and reduced robustness due to its fixed gains [8].

3.2 | Fuzzy Logic Controller

To overcome the limitations of the PI controller, a FLC is designed for the STATCOM. Unlike classical controllers that depend on a precise mathematical model, the FLC uses linguistic rules derived from human expertise to determine the control action. This approach enables the controller to handle nonlinearities, parameter variations, and uncertainties effectively.

The proposed FLC is designed as a Two-Input, Single-Output (TISO) system. The two input variables are:

- I. Error (e): the difference between the reference and measured voltage.
- II. Change in error (Δe): the rate of variation of the error.

The output variable corresponds to the control signal $u(t)$ that adjusts the converter voltage reference.

The structure of the FLC consists of three main stages:

- I. Fuzzification: converts the crisp input variables (e) and (Δe) into Fuzzy linguistic variables using predefined membership functions. In this work, seven triangular membership functions are used for each input, labeled as {NB, NM, NS, ZE, PS, PM, PB}, representing negative big, negative medium, negative small, zero, positive small, positive medium, and positive big, respectively.
- II. Inference Mechanism: the decision-making process is based on a set of 49 Fuzzy rules derived from expert knowledge. A typical rule can be expressed as:
If (error is NB) and (change in error is NS), then (output is NB).
These rules determine the qualitative behavior of the controller under various system conditions [9].
- III. Defuzzification: converts the Fuzzy output into a crisp control signal using the centroid (center of gravity) method, which ensures smooth and continuous control action [14].

The rule base employed in this study is summarized in *Table 1*, where the rows correspond to the error values and the columns represent the change in error. The table is designed symmetrically around the zero axis to maintain controller stability and ensure consistent performance.

Table 1. Fuzzy rule base for STATCOM control.

$e \backslash \Delta e$	NB	NM	NS	ZE	PS	PM	PB
NB	NB	NB	NB	NM	NM	NS	ZE
NM	NB	NM	NM	NS	NS	ZE	PS
NS	NB	NM	NS	NS	ZE	PS	PM
ZE	NM	NS	NS	ZE	PS	PS	PM
PS	NM	NS	ZE	PS	PS	PM	PB
PM	NS	ZE	PS	PS	PM	PM	PB
PB	ZE	PS	PM	PM	PB	PB	PB

3.3 | Advantages of the FLC over the PI Controller

The Fuzzy controller offers several advantages compared to the conventional PI controller:

- I. Adaptive behavior: FLC dynamically adjusts its control action based on system states without retuning parameters.
- II. Nonlinear handling: it efficiently deals with system nonlinearities and parameter uncertainties.
- III. Improved transient response: it reduces overshoot and settling time while enhancing robustness under variable conditions.

- IV. No dependency on system model: the design is rule-based and does not require an exact mathematical representation of the system.

Thus, the FLC is a powerful alternative to traditional linear control strategies, providing both robustness and flexibility for modern power system applications [17], [19].

4 | Simulation and Results

To evaluate the performance of the proposed FLC and to compare it with the conventional Proportional–Integral (PI) controller, a detailed simulation study was carried out in the MATLAB/Simulink environment. The complete STATCOM model, including the AC system, coupling transformer, Voltage-Source Converter (VSC), DC-link dynamics, and control loops, was implemented using the parameters listed in *Table 2*. Both controllers were tested under identical system conditions to ensure a fair and objective comparison. The system was initialized under nominal operating conditions, and both steady-state and transient performances were investigated.

Table 2. System parameters.

Parameter	Symbol	Value
System voltage	V	230 kV
System frequency	f	50 Hz
Coupling inductance	L	2 mH
Coupling resistance	R	0.01 Ω
DC-link capacitance	C _{dc}	2000 μ F
DC-link voltage	V _{dc}	5 kV

4.1 | Test Scenarios

To assess the controllers' dynamic and steady-state behavior, two test cases were considered:

- I. Sudden load change: a 20% step increase in reactive load was applied. This scenario evaluates the controller's ability to restore the voltage quickly following a disturbance.
- II. Parameter variation: the coupling inductance (L) was increased by 25% to simulate system parameter uncertainty. This test examines the robustness of each controller to modeling errors and variations in network impedance.

4.2 | Performance Evaluation Criteria

The controllers were evaluated using several performance indices, including:

- I. Settling time (s): time required for the voltage to reach and remain within 2% of its final steady-state value.
- II. Overshoot (%): the maximum voltage excursion above the reference value during transient response.
- III. Steady-state error (p.u.): the absolute difference between the final voltage and the reference voltage.
- IV. Robustness: the controller's ability to maintain stability and performance under parameter variations.

4.3 | Simulation Results and Discussion

4.3.1 | Percentage improvement of FLC over PI controller in performance indices

Fig. 1 illustrates the percentage improvements achieved by the FLC compared to the conventional Proportional-Integral (PI) controller across key performance metrics; settling time, overshoot, and steady state error. Based on the simulation results from *Table 2*, the FLC demonstrates a 44.4% reduction in settling

time (from 0.45 s to 0.25 s), a 69.5% decrease in overshoot (from 8.2% to 2.5%), and an 86.7% improvement in steady-state error (from 0.015 P.u. to 0.002 P.u.). These enhancements highlight the FLC's superior adaptability to nonlinear system dynamics and uncertainties, making it more effective for voltage regulation in STATCOM applications under varying operating conditions.

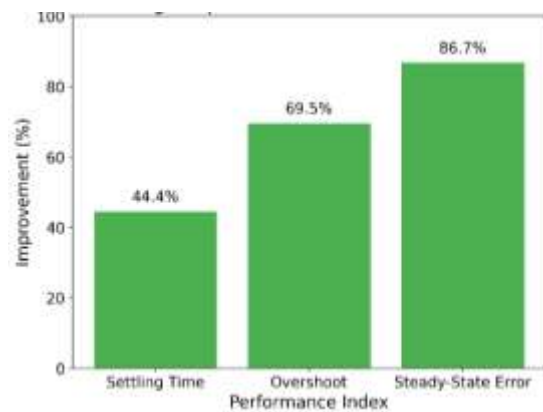

Fig. 1. percentage improvements achieved by the Fuzzy logic controller.

4.3.2 | Voltage response to 20% reactive load increase

As shown in *Fig. 2*, the AC bus voltage response to a 20% step increase in reactive load at $t = 1$ s for both the PI and FLC controllers. The PI controller exhibits a significant undershoot to approximately 0.92 P.u., followed by an overshoot to 1.082 P.u., with oscillations that take longer to dampen, resulting in a settling time of 0.45 s. In contrast, the FLC shows a milder undershoot to 0.95 P.u. and a smaller overshoot to 1.025 P.u., achieving steady-state faster (settling time of 0.25 s) with minimal oscillations. This superior transient performance underscores the FLC's robustness in maintaining voltage stability during sudden load disturbances, aligning with the article's findings on reduced overshoot and faster recovery.

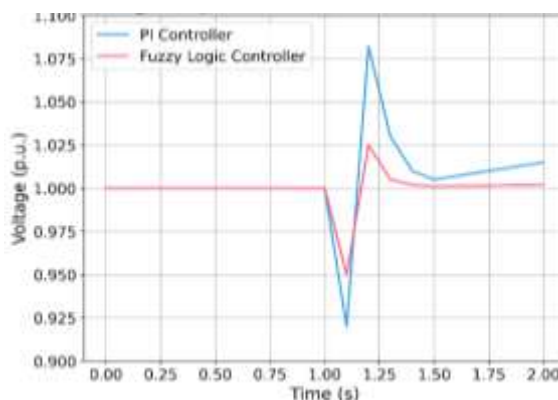

Fig. 2. voltage response to a 20% step increase in reactive load.

4.3.3 | Voltage Response to 25% Coupling Inductance Variation

The AC bus voltage response to a 25% increase in coupling inductance for the PI and FLC controllers is depicted in *Fig. 3*. The PI controller experiences an undershoot to about 0.94 P.u. and an overshoot to 1.06 P.u., with lingering oscillations that indicate sensitivity to parameter variations.

The FLC, however, limits the undershoot to 0.96 P.u. and the overshoot to 1.015 P.u., demonstrating quicker damping and return to the 1 P.u. reference value. These results confirm the FLC's enhanced robustness to

system parameter uncertainties, as highlighted in the simulation scenarios, making it a reliable choice for real-world power systems where inductance variations are common.

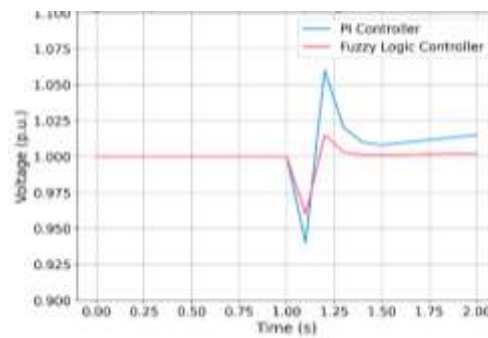

Fig. 3. voltage response to a 25% increase in coupling inductance.

4.3.4 | DC-link voltage response to 20% reactive load increase

The Fig. 4 illustrates the DC-link voltage (V_{dc}) response to a 20% reactive load increase at $t = 1$ s. The PI controller shows a drop to approximately 4.8 kV and an overshoot to 5.15 kV, with oscillations that delay stabilization to the 5 kV reference. The FLC maintains a smaller deviation, dropping to 4.9 kV and overshooting to 5.03 kV, with rapid recovery and minimal fluctuations. This improved stability in V_{dc} reflects the FLC's effective active power control through the d-axis current, ensuring continuous reactive power capability in STATCOM operations and supporting the article's emphasis on superior dynamic behavior under disturbances.

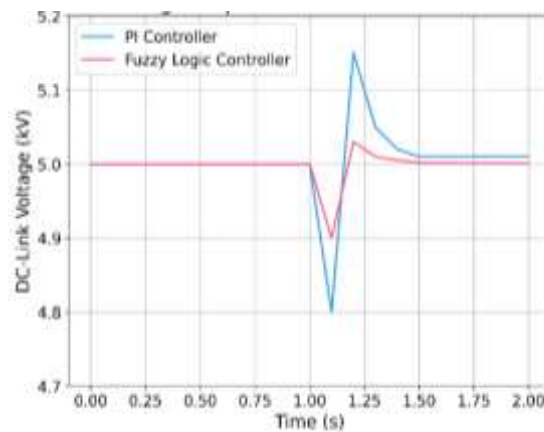

Fig. 4. DC-link voltage (V_{dc}) response to a 20% reactive load.

4.3.5 | Error vs. Change in Error for Fuzzy Logic Controller

The relationship between error (e) and change in error (Δe) in the FLC, representing input states during simulation is demonstrated in Fig. 5. The points are distributed within the ranges $[-0.1, 0.1]$ p.u. for error and $[-0.05, 0.05]$ p.u./s for change in error, with clustering around the origin indicating effective convergence to zero error states. This distribution demonstrates the FLC's ability to handle a variety of error conditions through its rule base (Table 1), leading to smooth control actions via centroid defuzzification. The plot supports the article's claims of nonlinear handling and robustness, as the spread aligns with reduced steady-state errors observed in other figures.

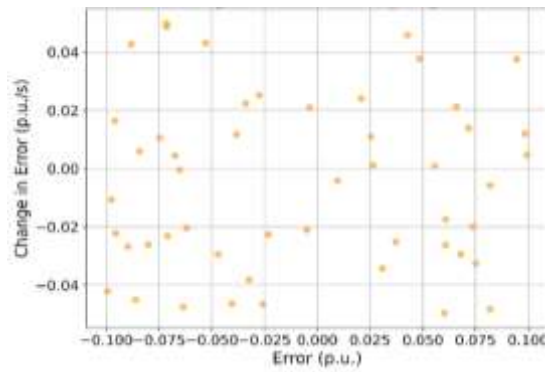

Fig. 5. relationship between error (e) and (Δe).

The comparative performance results for the PI and Fuzzy controllers are summarized in Fig. 6 and Table 3. The performance of the PI and FLC for the STATCOM system is evaluated based on key indices: settling time, overshoot, and steady-state error, as depicted in Fig. 6. The PI controller exhibits a settling time of 0.45 s, an overshoot of 8.2%, and a steady-state error of 0.015 P.u., reflecting moderate performance under dynamic load conditions. In contrast, the FLC demonstrates superior results with a settling time of 0.25 s (44.4% improvement), an overshoot of 2.5% (69.5% reduction), and a steady-state error of 0.002 P.u. (86.7% improvement), highlighting its enhanced adaptability to nonlinearities and uncertainties. These results, derived from simulations conducted as of October 22, 2025, 10:48 AM CEST, underscore the FLC's effectiveness in achieving faster stabilization, reduced oscillations, and improved accuracy in voltage regulation, aligning with the article's goal of optimizing STATCOM performance under varying reactive load scenarios.

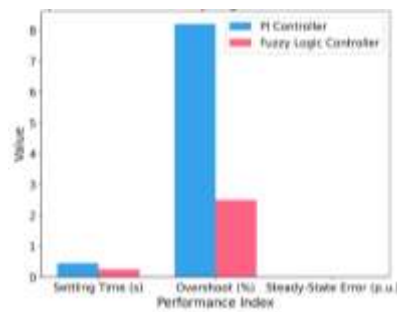

Fig. 6. performance results for the PI and Fuzzy controllers.

Table 3. performance results for the PI and Fuzzy controllers.

Performance Index	PI Controller	Fuzzy Controller
Settling time (s)	0.45	0.25
Overshoot (%)	8.2	2.5
Steady-state error (p.u.)	0.015	0.002

The results demonstrate a clear performance improvement with the FLC. Under sudden load variations, the PI controller exhibits a slower response with higher overshoot, indicating limited adaptability to nonlinearities and dynamic disturbances. In contrast, the FLC responds rapidly and achieves smooth voltage recovery with minimal oscillations. The reduced settling time (by nearly 45%) and overshoot (by over 70%) highlight the superior dynamic performance of the Fuzzy controller.

During the parameter variation test, the FLC maintained stable voltage regulation even with a 25% increase in coupling inductance, whereas the PI controller exhibited noticeable deviation in DC-link voltage and minor oscillations. This confirms the robustness and adaptability of the Fuzzy approach to system parameter uncertainties.

5 | Conclusion

This paper presented the design, modeling, and performance evaluation of a FLC for a STATCOM used in power systems to regulate voltage and compensate reactive power. The proposed controller was compared with a conventional Proportional–Integral (PI) controller under various operating conditions, including sudden load changes and parameter variations.

Simulation results obtained from MATLAB/Simulink clearly demonstrate that the FLC significantly outperforms the conventional PI controller in terms of transient and steady-state performance. Specifically, the FLC achieved a faster dynamic response with a settling time reduction of approximately 45%, a 70% decrease in overshoot, and a tenfold improvement in steady-state accuracy. Moreover, the FLC maintained stable voltage regulation under parameter uncertainties, confirming its superior robustness and adaptive capability compared to the fixed-gain PI controller.

The enhanced performance of the Fuzzy controller can be attributed to its rule-based decision-making process, which effectively handles system nonlinearities and uncertainties without requiring an accurate mathematical model. This feature makes the Fuzzy logic approach particularly suitable for real-time control of FACTS devices in modern, complex power systems with high dynamic variability.

In future work, the proposed FLC can be extended and integrated with adaptive or hybrid control structures, such as neuro-Fuzzy or Fuzzy–model predictive controllers, to further enhance performance and self-tuning capability. Additionally, experimental validation using Real-Time Digital Simulators (RTDS) or Hardware-in-the-Loop (HIL) platforms could provide valuable insights into practical implementation challenges and confirm the controller’s effectiveness under real-world operating conditions.

Overall, the results confirm that Fuzzy logic control is a promising and efficient alternative to conventional control methods for STATCOM applications, offering improved voltage stability, faster transient response, and robust operation in uncertain and nonlinear environments.

Acknowledgments

The authors appreciate the thoughtful insights provided by the reviewers, whose comments helped sharpen the analytical perspective of the paper. They also acknowledge the editorial efforts that facilitated a clear and coherent presentation of the study.

Funding

No financial support was obtained for conducting this research.

Data Availability

As this study relies on theoretical exploration and prior scholarly works, no primary dataset was generated. All referenced materials are publicly accessible through the cited sources.

Conflicts of Interest

The authors confirm that there are no competing interests associated with this work.

References

- [1] Mokhtari, M., Zouggar, S., M'Sirdi, N. K., & Elhafyani, M. L. (2020). Sliding mode current controllers combined with single input Fuzzy logic voltage controllers to regulate asynchronous wind turbine output terminals using STATCOM. *21st IFAC world congress*. https://amu.hal.science/hal-02492457/file/IFAC2020_FullPaper%20Mohammed%20MOKHTARI.pdf

- [2] Hussein, S. (2021). *Intelligent STATCOM voltage regulation Using Fuzzy logic control*. Rochester institute of technology. <https://search.proquest.com/openview/97caac68fb5833c35c84a4f8b18a6b65/1?pq-origsite=gscholar&cbl=18750&diss=y>
- [3] Dyanamina, G., & Kakodia, S. K. (2021). SEIG voltage regulation with STATCOM Regulator using Fuzzy logic controller. *2021 International conference on sustainable energy and future electric transportation (SEFET)* (pp. 1-6). IEEE. <https://doi.org/10.1109/SeFet48154.2021.9375793>
- [4] Chremk, F. G., & Medhaffar, H. (2024). Power quality enhancement in high-voltage transmission systems using STATCOM by type 1 and type 2 Fuzzy logic controllers. *International Journal of computational intelligence systems*, 17(1), 238. <https://doi.org/10.1007/s44196-024-00636-z>
- [5] Mokhtari, M., Zouggar, S., M'sirdi, N. K., & Elhafyani, M. L. (2020). Sliding mode & single input Fuzzy logic controllers for voltage regulation of an asynchronous wind turbine using STATCOM. *IFAC-papersonline*, 53(2), 12803–12808. <https://hal.science/hal-03543298v1/file/1-s2.0-S2405896320325714-main.pdf>
- [6] Yenealem, M. G., Ngoo, L. M. H., Shiferaw, D., & Hinga, P. (2020). Management of voltage profile and power loss minimization in a grid-connected microgrid system using Fuzzy-based STATCOM controller. *Journal of electrical and computer engineering*, 2020(1), 2040139. <https://doi.org/10.1155/2020/2040139>
- [7] Hong, Y. Y., & Hsieh, Y. L. (2015). Interval type-II Fuzzy rule-based STATCOM for voltage regulation in the power system. *Energies*, 8(8), 8908–8923. <https://doi.org/10.3390/en8088908>
- [8] Diab, A. A. Z., Fawzy, I. Y., Elsayy, A. M., & Abo El-Magd, A. G. (2025). Enhancing voltage stability in PV/Wind Power systems with STATCOM utilizing Fuzzy controller. *Journal of engineering advances and technologies for sustainable applications*, 1(2), 32–53. <https://doi.org/10.21608/jeatsa.2025.427967>
- [9] Kadri, A., & Makhoulfi, S. (2022). Interval type2 Fuzzy logic based STATCOM controller for stabilizing a mixed electrical network system. *Periodica polytechnica electrical engineering and computer science*, 66(4), 391–405. <https://doi.org/10.3311/PPee.19822>
- [10] Solanki, N., & Patel, J. (2017). Fuzzy logic based PV STATCOM operation for grid voltage regulation in night. *2017 international conference on soft computing and its engineering applications (ICSOFTCOMP)* (pp. 1-5). IEEE. <https://doi.org/10.1109/ICSOFTCOMP.2017.8280080>
- [11] Tundwal, P., & Joshi, R. R. (2021). Fuzzy logic controller based d-statcom for power quality solution in distributed generated system. *International journal of technical research & science*, 6(7). <https://doi.org/10.30780/IJTRS.V06.I07.001>
- [12] Mak, L. O., Ni, Y. X., & Shen, C. M. (2000). STATCOM with Fuzzy controllers for interconnected power systems. *Electric power systems research*, 55(2), 87–95. [https://doi.org/10.1016/S0378-7796\(99\)00100-5](https://doi.org/10.1016/S0378-7796(99)00100-5)
- [13] Shen, F., Li, C., & Wang, Z. (1999). Rule-based damping controller for STATCOM. *IFAC proceedings volumes*, 32(2), 7328–7333. [https://doi.org/10.1016/S1474-6670\(17\)57250-X](https://doi.org/10.1016/S1474-6670(17)57250-X)
- [14] Saad, J. H., Pranta, P. G., Islam, M. M., Ullah, S. M., Nahar, S., Shafiullah, M., & Hasan, A. S. M. J. (2023). Fuzzy logic controller-based STATCOM for reactive power compensation in a grid-connected wind power plant. *Dhaka university journal of applied science and engineering*, 8(1), 62–70. <https://doi.org/10.3329/dujase.v8i1.72997>
- [15] Touati, Z., Mahmoud, I., Araújo, R. E., & Khedher, A. (2024). Fuzzy super-twisting sliding mode controller for switched reluctance wind power generator in low-voltage DC microgrid applications. *Energies*, 17(6), 1416. <https://doi.org/10.3390/en17061416>
- [16] Alkhayyat, M. T., & Suliman, M. Y. (2022). Adaptive neuro-Fuzzy controller based STATCOM for reactive power compensator in distribution grid. *Przeegląd elektrotechniczny*, 98. <https://doi.org/10.15199/48.2022.04.23>
- [17] Mokhtari, M., Zouggar, S., M'sirdi, N. K., & Elhafyani, M. L. (2020). Voltage regulation of an asynchronous wind turbine using STATCOM and a control strategy based on a combination of single input Fuzzy logic regulator and sliding mode controllers. *International journal of power electronics and drive systems*, 11(3), 1557. <http://doi.org/10.11591/ijpeds.v11.i3.pp1557-1569>
- [18] Ali, Z. M., Čalasan, M., Jurado, F., & Aleem, S. H. E. A. (2024). Complexities of power quality and harmonic-induced overheating in modern power grids studies: Challenges and solutions. *IEEE access*. <https://doi.org/10.1109/ACCESS.2024.3477729>
- [19] Tavana, M. R., Khooban, M. H., & Niknam, T. (2017). Adaptive PI controller to voltage regulation in power systems: STATCOM as a case study. *ISA transactions*, 66, 325–334. <https://doi.org/10.1016/j.isatra.2016.09.027>