



Paper Type: Original Article

## A Comprehensive Study of the Principles and Trends in AC Circuits: Essential Component in Electromechanical Systems and Industries

Kufre Recharad Ekanem<sup>1,\*</sup>, Imoh Ime Ekanem<sup>2</sup>, Aniekan Essienubong Ikpe<sup>2</sup>

<sup>1</sup> Department of Science Technology, Akwa Ibom State Polytechnic, Ikot Osurua, PMB 1200, Nigeria; kufre.ekanem@akwaibompoly.edu.ng.

<sup>2</sup> Department of Mechanical Engineering, Akwa Ibom State Polytechnic, Ikot Osurua, PMB. 1200, Nigeria; imoh.ekanem@akwaibompoly.edu.ng; aniekan.ikpe@akwaibompoly.edu.ng.

Citation:

Received: 17 June 2024

Revised: 29 June 2024

Accepted: 10 July 2024

Ekanem, K. R., Ekanem, I. I., & Ikpe, A. E. (2024). A comprehensive study of the principles and trends in AC circuits: essential components in electromechanical systems and industries. *Management analytics and social insights*, 1(1), 17-38.

### Abstract

The need for efficient and reliable power transmission and control in various electromechanical industrial and commercial settings has driven the evolution of Alternating Current (AC) circuits in electromechanical applications. With the increasing demand for automation and electrification in modern society, the development of AC circuits has become crucial for operating a wide range of electromechanical systems. Critical challenges in the evolution of AC circuits are balancing the conflicting efficiency, reliability, and cost-effectiveness requirements. As electromechanical systems become more complex and interconnected, the design and implementation of AC circuits require astute optimization to ensure effective performance and safety. A detailed literature review was conducted concerning relevant research articles, textbooks, and technical documents on the evolution of AC circuits in electromechanical applications. The selected sources were analyzed to extract critical information on the advancements in AC circuits and their implications in electromechanical industries. The literature review revealed significant developments in AC circuits, including the introduction of solid-state devices, digital control systems, and advanced power electronics. These advancements have improved efficiency, reliability, and performance in electromechanical systems. For example, using variable frequency drives has enabled precise motor speed and torque control, resulting in energy savings and reduced maintenance costs. Furthermore, integrating smart grid technologies has enhanced the monitoring and management of power distribution systems, leading to improved reliability and stability. Hence, the evolution of AC circuits has profoundly impacted the design and operation of electromechanical systems, paving the way for more efficient and sustainable technologies.

**Keywords:** AC circuits, Electromechanical industries, System stability, Power transmission.

## 1 | Introduction

An electric circuit is a closed path or loop through which charges or electric current flow continuously. It is a closed conducting path for electrons, also known as an electrical circuit or electrical network. In electricity, circuits can be found in various types, such as open, closed, series, parallel, etc. An AC circuit is a type of

✉ Corresponding Author: kufre.ekanem@akwaibompoly.edu.ng



Licensee System Analytics. This article is an open access article distributed under the terms and conditions of the Creative Commons Attribution (CC BY) license (<http://creativecommons.org/licenses/by/4.0>).

electric circuit. Alternating Currents (ACs) and voltages are sinusoidal and vary with time. ACs produce different responses in resistors, capacitors, and inductors than Direct Currents (DCs) do [1]. AC circuits are a fundamental aspect of electrical engineering and play a crucial role in powering a wide range of devices and systems. AC circuits are electrical circuits that utilize AC, a type of electrical current that periodically changes direction. Unlike DC circuits, which have a constant flow of current in one direction, AC circuits have a flow of current that alternates between positive and negative directions [2]. This AC flow is typically represented by a sine wave, with the wave's frequency determining the rate at which the current changes direction. The critical characteristic of AC circuits is their ability to change voltage levels using transformers easily. With transformers, AC circuits can efficiently step up or down voltage levels, making them ideal for transmitting electricity over long distances. This contrasts with DC circuits, which require more complex and less efficient methods to change voltage levels.

AC circuits are used in a wide range of applications, including power distribution systems, electric motors, and household appliances [3]. The ability of AC circuits to easily change voltage levels and transmit electricity over long distances makes them essential for powering our modern society. Distributing electricity to homes, businesses, and industries without AC circuits would be much more complex and costly. AC circuits is vital to modern technology and crucial to powering our everyday lives [4]. Their ability to efficiently change voltage levels and transmit electricity over long distances makes them essential for a wide range of applications. As we continue to rely on electricity for our daily needs, the importance of AC circuits will only continue to grow.

## 2 | Early Experiments and Discoveries

Before the development of AC circuits, DC was the dominant form of electrical power transmission. However, DC systems were limited in transmitting electricity over long distances, as the voltage drop over the transmission lines was significant. This limitation led to the development of AC circuits, allowing electricity transmission at higher voltages and lower currents, reducing energy losses over long distances. The story of AC circuits begins in the early 19th century with the pioneering work of Michael Faraday [5]. Faraday's experiments with electromagnetic induction laid the foundation for developing AC power systems. His discovery that a changing magnetic field could induce an electric current in a wire paved the way for developing AC generators and transformers. One of the key figures in the history of AC circuits is Nikola Tesla, a Serbian-American inventor credited with developing the modern AC system [6]. Tesla's work on AC circuits laid the foundation for the widespread adoption of AC as the standard for electrical power distribution. Building on Faraday's work, Nikola Tesla significantly contributed to AC circuits in the late 19th and early 20th centuries. Tesla's development of the polyphase AC system revolutionized the transmission and distribution of electrical power [7]. His invention of the Tesla coil and the development of the first AC motor were groundbreaking achievements that paved the way for the widespread adoption of AC power systems. The development of AC circuits can be traced back to the late 19th century when inventors and engineers explored ways to transmit electricity over long distances more efficiently. The battle between AC and DC systems peaked during the War of Currents in the late 19th century, with Thomas Edison advocating for DC systems and Nikola Tesla and George Westinghouse championing AC systems [8]. Ultimately, AC circuits emerged as the superior technology due to their ability to transmit electricity over long distances more efficiently. Today, AC circuits are the standard for electrical power distribution worldwide, powering everything from homes and businesses to industrial machinery and transportation systems. The development of AC circuits has profoundly impacted society, enabling the widespread adoption of electrical appliances and devices that have transformed how we live and work.

## 3 | Advancements in Power Distribution

The development of AC circuits also played a crucial role in the advancement of power distribution systems, which include:

- I. The introduction of high-voltage transmission lines and the development of transformers allowed for the efficient transmission of electricity over long distances. This led to the establishing of centralized power plants and the widespread electrification of cities and towns [9].
- II. Adopting AC circuits also enabled the development of new technologies and industries. [10].
- III. The availability of reliable and affordable electricity spurred the growth of the manufacturing sector and fueled the rise of the consumer electronics industry. The development of AC circuits has profoundly impacted society, transforming how we live, work, and communicate [11].

The history of AC circuits is a testament to the power of human ingenuity and innovation. From the early experiments of Faraday and Tesla to the development of modern power distribution systems, the evolution of AC circuits has been marked by significant advancements and breakthroughs. The development of AC circuits by pioneers like Nikola Tesla has paved the way for efficient electricity transmission over long distances, revolutionizing how humanity operates [12]. As the world continues to rely on AC circuits for its electrical needs, it is essential to remember this groundbreaking technology's rich history and legacy.

## 4 | Key Milestones and Dates

Some of the most significant milestones in the history of AC circuit technology are highlighted as follows:

- I. The invention of the AC generator by Nikola Tesla in 1887 marked the beginning of the widespread use of AC power systems, which are now the standard for electricity generation and distribution worldwide. Tesla's AC generator was a significant breakthrough in electrical engineering, allowing for efficient electricity transmission over long distances [13], [14].
- II. The development of the first AC power transmission system by George Westinghouse in 1893, which used high-voltage transmission lines to carry electricity over long distances, revolutionized how power was distributed and made it possible to supply electricity to remote areas. The success of Westinghouse's AC power transmission system paved the way for the widespread adoption of AC power systems in the following years [15].
- III. Another milestone during this period was the invention of the first practical AC motor by Charles Steinmetz in 1902. This motor, which used a rotating magnetic field to produce mechanical energy, was a significant breakthrough in electrical engineering and laid the foundation for the development of modern electric motors. [16].
- IV. Another key milestone was the development of solid-state devices such as transistors and diodes, which revolutionized the design of AC circuits and made it possible to build more compact and efficient power systems. These solid-state devices paved the way for the development of modern electronic devices and have played a crucial role in shaping the modern world [17].

The advancements in AC circuit technology have profoundly impacted society, enabling the widespread adoption of electricity and powering the modern world. Without these advancements, transmitting electricity over long distances, powering our homes and businesses, or driving technological innovation would not be possible. The advancements in AC circuit technology have also played a crucial role in shaping the modern world and have revolutionized how electricity is generated, transmitted, and used.

## 5 | Conventional Advancements in AC Circuit Technology

AC circuit technology has significantly improved efficiency, reliability and performance. These advancements have been driven by the need for more efficient power distribution systems, increased demand for renewable energy sources, and the development of new technologies. The key conventional advancements in AC circuit technology and their impact on the industry are outlined as follows:

- I. Advancements in power electronics: power electronics devices such as inverters, rectifiers, and converters are crucial in converting and controlling electrical power in AC circuits. These devices have become more efficient and reliable over the years, improving performance and reducing energy losses in power distribution

systems. For example, the development of Insulated Gate Bipolar Transistors (IGBTs) and Silicon Carbide (SiC) devices has enabled higher switching frequencies and lower losses in power electronic converters [18]. This has improved efficiency and power density in AC circuits, making them more suitable for high-power applications such as electric vehicles and renewable energy systems.

- II. Advancements in grid integration: with the increasing demand for clean energy, there has been a growing need to integrate solar, wind, and other renewable sources into existing AC power systems. This has led to the developing of advanced grid-tied inverters and power management systems that can efficiently integrate renewable energy sources into the grid [19]. Grid-tied inverters are designed to convert DC power from solar panels or wind turbines into AC power that can be fed back into the grid. These inverters use advanced control algorithms to ensure stable and reliable operation, even with fluctuating renewable energy inputs. This has enabled the widespread adoption of solar and wind power systems, leading to a more sustainable and environmentally friendly energy mix [20].
- III. Advancements in smart grid technologies: the development of smart grid technologies has also significantly impacted AC circuit technology. Smart grids use advanced communication and control systems to monitor and optimize power distribution in real-time, leading to improved efficiency and reliability in AC circuits [21]. These technologies enable utilities to manage power flows better, reduce peak demand, and integrate renewable energy sources into the grid. For example, Advanced Metering Infrastructure (AMI) systems allow utilities to remotely monitor and control power consumption in real-time, leading to more efficient energy management and reduced consumer costs. Similarly, grid automation technologies enable utilities to quickly detect and respond to power outages, improving reliability and reducing customer downtime [13].

Conventional advancements in AC circuit technology have improved efficiency, reliability, and performance in power distribution systems. The development of power electronics, grid integration technologies, and smart grid systems has enabled the widespread adoption of renewable energy sources and the optimization of power distribution networks. These advancements will continue to drive innovation in the industry, leading to a more sustainable and efficient energy future [22], [23].

## 6 | Characteristics of AC Circuits

AC circuits are a fundamental component of electrical engineering and play a crucial role in powering a wide range of devices and systems. Understanding the key distinguishing characteristics of AC circuits is essential for engineers and technicians working in electrical engineering. This section deals with the significant distinguishing characteristics of AC circuits and highlights their importance in electrical systems.

- I. Frequency: AC circuits operate at a specific frequency, measured in hertz (Hz). The frequency of an AC circuit determines the rate at which the current alternates direction and it is a crucial parameter that must be carefully controlled in electrical systems. Countries and regions may have different standard AC power grids, with 50 Hz and 60 Hz being the most common frequencies used worldwide [24].
- II. Voltage and current waveforms: in AC circuits, voltage and current vary sinusoidally with time, creating a waveform oscillating between positive and negative values. The AC circuit's voltage and current waveforms' amplitude are typically measured in volts (V) and amperes (A), respectively. The sinusoidal nature of AC waveforms allows for efficient transmission of electrical power over long distances and enables the operation of a wide range of electrical devices [25].
- III. Phase angle: in AC circuits, the phase angle between voltage and current waveforms is a critical parameter that determines the power factor of the circuit. The phase angle represents the time delay between the voltage and current waveforms and is measured in degrees. A phase angle of zero degrees indicates that the voltage and current waveforms are in phase, while a phase angle of 90 degrees indicates that the voltage and current waveforms are out of phase. Controlling the phase angle in AC circuits is essential for optimizing power transfer and minimizing energy losses in electrical systems.
- IV. Impedance: impedance is another crucial characteristic of AC circuits that determines the resistance of the circuit to the flow of AC. Impedance is a complex quantity that includes both resistance and reactance, which

is the opposition of a circuit to the flow of AC due to inductance and capacitance. Impedance is measured in ohms ( $\Omega$ ) and plays a crucial role in determining the performance of AC circuits, including voltage regulation, power factor correction, and efficiency [26].

Understanding the critical distinguishing characteristics of AC circuits is essential for engineers and technicians working in electrical engineering. The frequency, voltage and current waveforms, phase angle, and impedance are significant parameters that define the behaviour of AC circuits and play a crucial role in the design and operation of electrical systems.

## 7 | Types of AC Circuits

The various types of AC circuits (see *Fig. 1*) applicable to electromechanical components are highlighted as follows:

- I. Resistor capacitor AC circuit: the resistor-capacitor circuit comprises an AC generator, a resistor, and a capacitor. A capacitor is a collection of conductive plates separated by an insulating material. Therefore, the capacitor does not allow a consistent flow of electric current. An AC can either remove or introduce electric charges to the plates of a capacitor.
- II. Resistor Inductor (RI) AC circuit: the RI circuit consists of an AC generator, a resistor and an inductor. When the circuit switch is turned on in an RL AC circuit, a back Electromotive Force (EMF) is induced in the inductor coil. It takes a certain amount of time for the current to reach its maximum value. This time duration is referred to as the inductive time constant.
- III. Resistive (R) AC circuit: resistors serve as regulators that control, hinder, or establish the current flow in a particular direction or reduce voltage inside a circuit. Resistors possess an electrical property called impedance, defined explicitly as resistance (R). The resistance of a resistor is measured in Ohms ( $\Omega$ ). The calculation can be done using either a fixed or variable value, such as potentiometers.
- IV. Resistor Inductor Capacitor (RIC) AC circuit: the RIC AC circuit consists of a resistor R, an inductor L, and a capacitor C, connected in a series or parallel configuration. The voltage across the resistor aligns with the current flowing through it. The voltage across the inductor causes the current to lag by  $90^\circ$ . The voltage across the capacitor lags behind the current flowing through it.

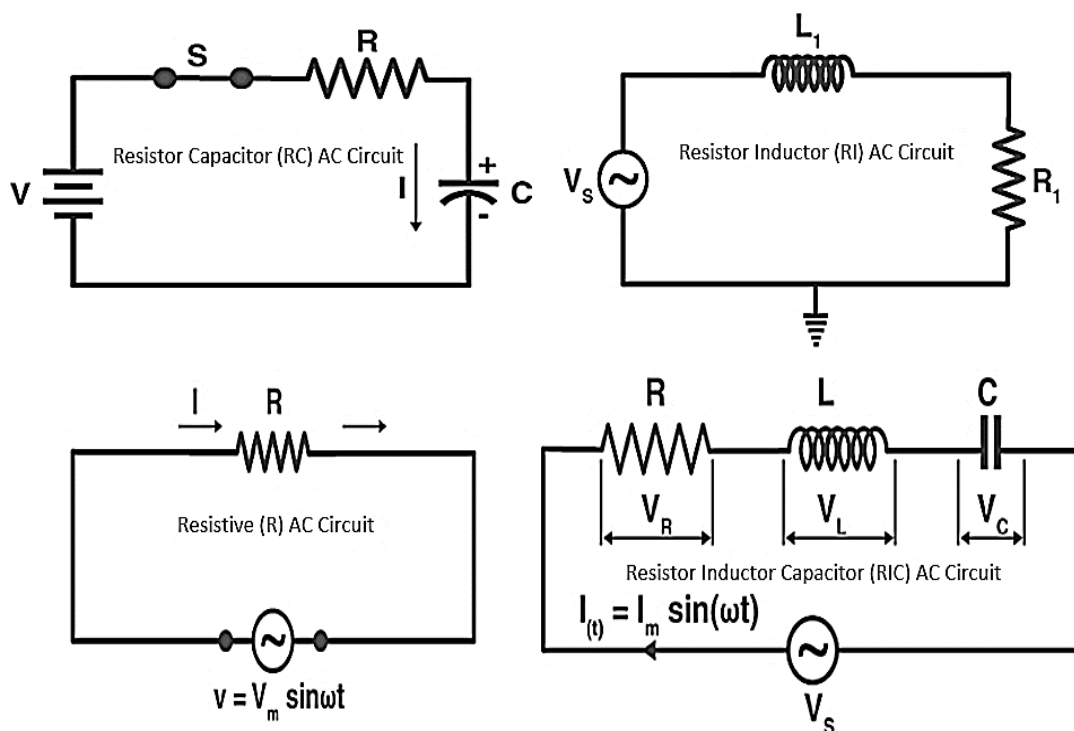

Fig. 1. Types of AC circuits [27].

## 8 | Types of AC Circuit Connection

AC circuits are an essential component of electrical engineering, providing power to a wide range of devices and systems. There are several types and classifications of AC circuits, each with unique characteristics and applications. The various types of AC circuit connections include series, parallel and series-parallel connections (see Fig. 2), highlighted as follows:

- I. Series: in a series AC circuit, the components are connected in a single loop, with the current flowing through each component in sequence. This type of circuit is commonly used in applications where the components need to be connected in a specific order, such as in a string of Christmas lights and the circuit is commonly used in applications where the components need to share the same current, such as in lighting systems or heating elements [28].
- II. Parallel: in a parallel AC circuit, the components are connected in multiple branches, each receiving the same voltage. This type of circuit is often used in applications where the components need to operate independently of each other, such as in a household electrical system, and the circuit is commonly used in applications where components need to share the same voltage, such as in power distribution systems or electronic devices [29].
- III. A series-parallel AC circuit combines elements of both series and parallel circuits, with some components connected in series and others connected in parallel. This type of circuit is commonly used in complex electrical systems, where different components need to be connected in different configurations, depending on the specific configuration of the circuit; this type of circuit is commonly used in applications where a combination of series and parallel connections is required, such as in complex electronic systems or power generation systems [30].

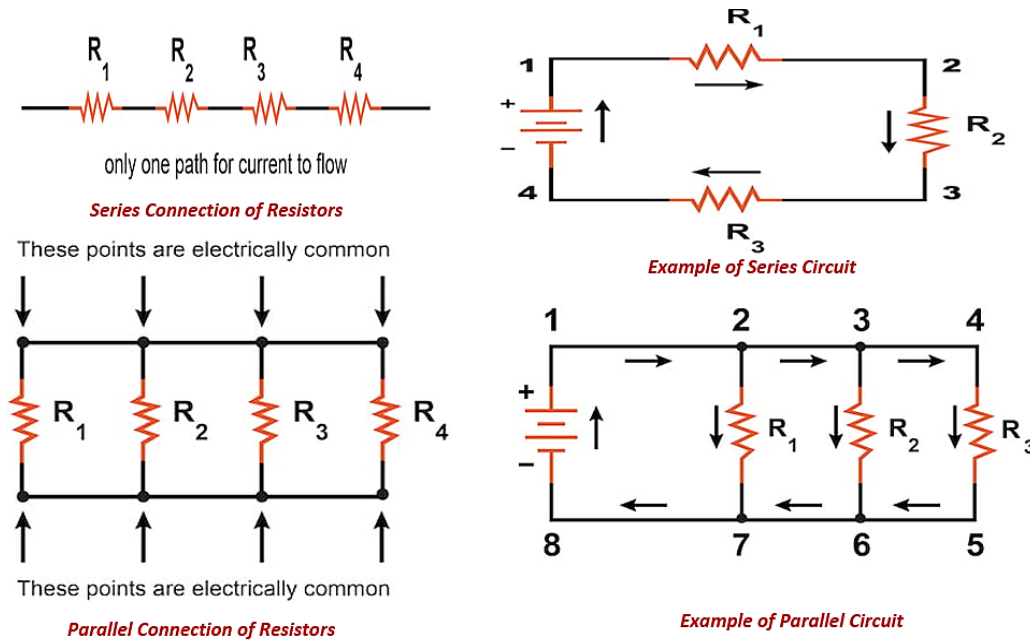

Fig. 2. Types of AC Circuits connection diagram [31].

Several types of AC circuits are commonly used in electrical engineering applications, each with unique properties and advantages. Series AC circuits are used when components need to share the same current, parallel AC circuits are used when components need to share the same voltage and combination AC circuits are used when a combination of series and parallel connections is required.

## 9 | Classifications of AC Circuits

AC circuits can also be classified based on the following:

- I. **The frequency:** the frequency of an AC circuit refers to the number of cycles per second that the current alternates in direction. AC circuits with frequencies below 20 Hz are considered low frequency, while those with frequencies above 20 kHz are considered high frequency [32].
- II. **Impedance:** impedance is another vital classification of AC circuits, referring to the total opposition to the current flow in a circuit. Impedance is measured in ohms and is influenced by the circuit's resistance, inductance, and capacitance. AC circuits with high impedance are more resistant to the flow of current, while those with low impedance allow current to flow more easily [33].
- III. **Power factor:** power factor measures how efficiently a circuit converts electrical power into valuable work. AC circuits with a power factor of 1 are considered perfectly efficient, while those with a power factor below 1 are less efficient. Power factor is influenced by the phase relationship between the voltage and current in a circuit, with circuits in phase having a power factor of 1 [34].
- IV. **The type of current flow:** in a purely resistive AC circuit, the current and voltage are in phase, meaning that they reach their peak values simultaneously. This type of circuit is characterized by a power factor of 1 and is commonly found in heating elements and incandescent light bulbs. On the other hand, inductive AC circuits contain inductors that cause the current to lag behind the voltage, resulting in a phase shift. On the other hand, capacitive AC circuits have capacitors that cause the current to lead to the voltage. These types of circuits are commonly used in power factor correction applications [35].
- V. **The presence of reactive components:** reactive components such as inductors and capacitors introduce impedance into the circuit, affecting the current flow. In AC circuits, the impedance combines resistance, inductive reactance, and capacitive reactance. The impedance of a circuit can be calculated using the formula  $Z = \sqrt{R^2 + (X_L - X_C)^2}$ , where  $R$  is the resistance,  $X_L$  is the inductive reactance,

and  $X_C$  is the capacitive reactance. By analyzing the impedance of a circuit, engineers can determine the circuit's behaviour and design appropriate solutions to optimize its performance [36].

- VI. Based on their configuration, series AC circuits have components connected in a single path, where the current flows through each component sequentially. In contrast, parallel AC circuits have components connected in multiple paths, where the current splits and flows through each component simultaneously (see *Fig. 2*). The behaviour of series and parallel AC circuits differs significantly, with series circuits having higher total impedance and parallel circuits having lower total impedance [37].

AC circuits are classified into various categories based on different criteria, such as the type of current flow, the presence of reactive components, and the configuration of the circuit. By considering factors such as the type of current flow, the presence of reactive components, and the configuration of the circuit, engineers can effectively design and optimize AC circuits for a wide range of applications.

## 10 | Operation Principles of AC Circuit

An AC circuit is a fundamental component of electrical systems, allowing for the transmission and distribution of electrical power. Understanding the operation principles of an AC circuit is crucial for engineers and technicians working in electrical engineering. This section will provide a detailed core description and explain how an AC circuit works. At its core, an AC circuit consists of three main components: a voltage source, a load, and connecting wires. The voltage source, typically an AC generator or power supply, produces an alternating voltage that varies sinusoidally with time. This alternating voltage is then applied to the load, which can be a resistor, capacitor, or inductor [38]. The load consumes electrical power and converts it into other forms of energy, such as heat or mechanical work. The principles of the following laws govern the operation of an AC circuit:

- I. Ohm's law: it states that the current flowing through a conductor is directly proportional to the voltage applied across it and inversely proportional to the resistance of the conductor. In an AC circuit, the load's impedance, including resistance and reactance, determines the current flowing through the circuit.
- II. Kirchhoff's laws, specifically Kirchhoff's voltage law and Kirchhoff's current law, are used to analyze the flow of current and voltage in an AC circuit. Kirchhoff's voltage law states that the sum of the voltages around a closed loop in a circuit is equal to zero, while Kirchhoff's current law states that the sum of currents entering a node in a circuit is equal to the sum of currents leaving the node.

In an AC circuit, the voltage and current waveforms are out of phase due to reactive components such as capacitors and inductors. The power factor describes the phase relationship between voltage and current, indicating the power transfer efficiency in the circuit. Power factor correction techniques, such as adding capacitors or inductors to the circuit, can improve the power factor and reduce energy losses. Understanding the operation principles of an AC circuit is essential for designing and troubleshooting electrical systems [39].

## 11 | Impedance in an AC Circuit

Impedance in an AC circuit is a crucial concept that plays a significant role in the analysis and design of electrical systems. It is defined as the opposition that an electrical circuit presents to the flow of AC. In simple terms, impedance is the AC equivalent of resistance in a DC circuit [40]. The critical differences between impedance and resistance are:

- I. Impedance takes into account both resistance and reactance.
- II. Reactance is the opposition to the flow of AC caused by inductance and capacitance in the circuit.
- III. Inductors create inductive reactance, which is proportional to the frequency of the AC signal, while capacitors create capacitive reactance, which is inversely proportional to the frequency.

The total impedance in an AC circuit is the vector sum of the resistance and reactance. It is represented by the symbol  $Z$  and is measured in ohms. The relationship between voltage, current, and impedance in an AC



circuit is described by Ohm's law for AC circuits, which states that the voltage across impedance is equal to the product of the current flowing through it and the impedance. Additionally, Impedance plays a crucial role in determining the behaviour of AC circuits. It affects the magnitude and phase of the current and voltage in the circuit. By manipulating the impedance of different components in a circuit, engineers can control the flow of current and voltage to achieve specific desired outcomes [41].

## 12 | Resistance in an AC Circuit

Resistance in an AC circuit is a crucial concept in electrical engineering. It refers to the opposition an electrical component or material offers to AC flow. This resistance is caused by the collisions of electrons with atoms in the material, which converts electrical energy into heat. The key characteristics of resistance in an AC circuit are highlighted as follows:

- I. It is frequency-dependent: this means that the resistance of a material or component can vary depending on the frequency of the AC passing through it. This is because, at higher frequencies, the collisions between electrons and atoms occur more frequently, leading to a higher resistance [42].
- II. Its effect on the power dissipation in the circuit: the power dissipated in a resistor in an AC circuit is given by the formula  $P = I^2R$ , where  $P$  is the power dissipated,  $I$  is the current flowing through the resistor, and  $R$  is the resistance of the resistor. This formula shows that the power dissipated in a resistor is directly proportional to the square of the current flowing through it and the resistance of the resistor.
- III. Resistance in an AC circuit also plays a crucial role in determining the impedance of the circuit. Impedance is the total opposition that a circuit offers to the flow of AC and is a combination of resistance, inductance, and capacitance. The impedance of a circuit is given by the formula  $Z = \sqrt{R^2 + (X_L - X_C)^2}$ , where  $Z$  is the impedance,  $R$  is the resistance,  $X_L$  is the inductive reactance, and  $X_C$  is the capacitive reactance. This formula shows that resistance is a fundamental component of the impedance of an AC circuit [43].

Resistance in an AC circuit is a fundamental concept in electrical engineering that plays a crucial role in determining the circuit's behaviour. It is frequency-dependent, affects power dissipation, and is a critical component of the impedance of the circuit.

## 13 | Reactance in AC circuit

Reactance is a fundamental concept in analyzing AC circuits. It is a measure of the opposition that a circuit element presents to the flow of AC. In an AC circuit, reactance can be either capacitive or inductive, depending on the type of circuit element involved.

- I. Capacitive reactance is a capacitor's opposition to the flow of AC. It is inversely proportional to the frequency of the AC signal and the capacitance of the capacitor. The formula for capacitive reactance is  $X_C = 1 / (2\pi fC)$ , where  $X_C$  is the capacitive reactance,  $f$  is the frequency of the AC signal, and  $C$  is the capacitance of the capacitor [41].
- II. Inductive reactance, on the other hand, is the opposition that an inductor presents to the flow of AC. It is directly proportional to the AC signal's frequency and the inductor's inductance. The formula for inductive reactance is  $X_L = 2\pi fL$ , where  $X_L$  is the inductive reactance,  $f$  is the frequency of the AC signal, and  $L$  is the inductance of the inductor.

In an AC circuit, reactance plays a crucial role in determining the overall impedance of the circuit. Impedance is the total opposition that a circuit element presents to the flow of AC and is the combination of resistance and reactance. The impedance of a circuit can be calculated using the formula  $Z = \sqrt{R^2 + (X_L - X_C)^2}$ , where  $Z$  is the impedance,  $R$  is the resistance of the circuit,  $X_L$  is the inductive reactance, and  $X_C$  is the capacitive reactance.

## 14 | Inductors in AC Circuit

Inductors are passive electrical components that store energy as a magnetic field when an AC flows through them. They are commonly used in AC circuits to control the flow of current and voltage. Inductors are typically made of a coil of wire wound around a core material, such as iron or ferrite. When an AC passes through the coil, a magnetic field is generated around it [29]. This magnetic field stores energy and opposes any changes in the current flowing through the inductor. This property is known as inductance, measured in henries (H). In AC circuits, inductors are used to control the flow of current and voltage. They can filter out unwanted frequencies, smooth out voltage fluctuations, and protect sensitive components from spikes. Inductors are also used in transformers to step up or down the voltage in AC power distribution systems. One of the critical characteristics of inductors in AC circuits is their ability to store energy and release it back into the circuit. This property is known as reactance, which is an inductor's opposition to changes in current flow. The reactance of an inductor is directly proportional to the frequency of the AC passing through it. Inductors play a crucial role in AC circuits by controlling the flow of current and voltage [44]. They store energy in a magnetic field and release it into the circuit.

## 15 | Capacitors in an AC Circuit

Capacitors are essential components in AC circuits, which are crucial in storing and releasing electrical energy. Some of the critical characteristics of capacitors in AC circuits are:

- I. A capacitor is a passive electronic component that consists of two conductive plates separated by an insulating material known as a dielectric. When connected to an AC power source, the capacitor charges and discharges in response to the changing voltage and current in the circuit [45]. This ability to store and release electrical energy makes capacitors worthwhile in various applications, including filtering, timing, and energy storage.
- II. In an AC circuit, capacitors exhibit unique behaviour due to their ability to store and release energy in response to alternating voltage. When connected in series with a load, capacitors block DC while allowing AC to pass through. This property makes capacitors ideal for coupling and decoupling signals in electronic circuits [46].
- III. Capacitors can also be used to create phase shifts in AC circuits. By connecting a capacitor in parallel with a load, the voltage across the capacitor leads the current, creating a phase difference between the two. This phase shift can control the power factor in AC circuits, improving efficiency and reducing energy consumption [38].

Some circuits are characterized by only one capacitor and an AC power source (see *Fig. 3*), yet they still perform optimally depending on the requirements. However, this attribute may differ in other circuit configurations. Capacitors are essential components in AC circuits, providing energy storage, filtering, and phase-shifting capabilities. Understanding the behaviour of capacitors in AC circuits is crucial for designing efficient and reliable electronic systems. By harnessing the power of capacitors, engineers and designers can create innovative solutions for a wide range of applications.

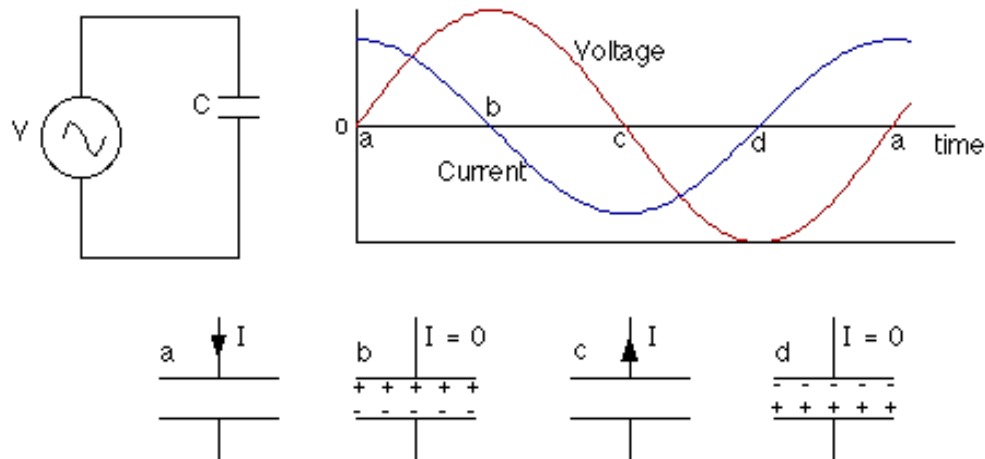

Fig. 3. Circuit with only one capacitor and an AC power source [47].

## 16 | Current in an AC Circuit

In an AC circuit, current flows in a constantly changing direction. This contrasts DC circuits, where current flows in only one direction. Its amplitude, frequency and phase characterize the current flow in an AC circuit. The amplitude of the current in an AC circuit refers to the maximum value of the current as it oscillates back and forth. This value is typically measured in amperes (A) and can vary depending on the voltage and resistance in the circuit [48]. The current frequency in an AC circuit refers to the number of complete current cycles per second, measured in hertz (Hz). In most household circuits, the frequency is typically 60 Hz. The phase of the current in an AC circuit refers to the relationship between the current and voltage waveforms. In an ideal AC circuit, the current and voltage are said to be in phase, meaning they reach their maximum and minimum values simultaneously. However, in real-world circuits, the current and voltage may be out of phase due to inductance and capacitance. The key advantages of AC circuits are:

- I. Its ability to easily change voltage levels using transformers. This allows for efficient transmission of electricity over long distances and the ability to step up or down voltage levels as needed.
- II. AC circuits are more versatile than DC circuits, as they can be easily converted to DC using rectifiers.

The current flow in an AC circuit is characterized by its amplitude, frequency, and phase. Understanding these characteristics is essential for designing and analyzing AC circuits. By harnessing the power of AC circuits, we can efficiently transmit electricity and power a wide range of devices and systems.

## 17 | Voltage in an AC circuit

Voltage in an AC circuit is a crucial concept in electrical engineering. It is defined as the difference in electric potential between two points in the circuit and is measured in volts. In an AC circuit, the voltage constantly changes direction and magnitude, unlike in a DC circuit where the voltage remains constant. The critical characteristics of voltage in an AC circuit are stated below:

- I. Its sinusoidal waveform: the voltage varies sinusoidally with time, oscillating between positive and negative values. The peak voltage, or amplitude, is the maximum value the voltage reaches during each cycle. The frequency of the voltage waveform is the number of complete cycles that occur in one second and is measured in hertz (Hz) [49].
- II. The concept of phase: this is also important in understanding voltage in an AC circuit. Phase refers to the relationship between the circuit's voltage waveform and current waveform. When the voltage and current waveforms are in phase, they reach their peak values simultaneously. When they are out of phase, the peak values occur at different times [50].

III. Phasor diagrams: in an AC circuit, the voltage can be described using phasor diagrams (see Fig. 4). Phasors are vectors that represent the magnitude and phase of the voltage at a specific point in the circuit. By analyzing the phasor diagrams, engineers can determine the relationship between voltage and current and calculate essential parameters such as power and impedance [51].

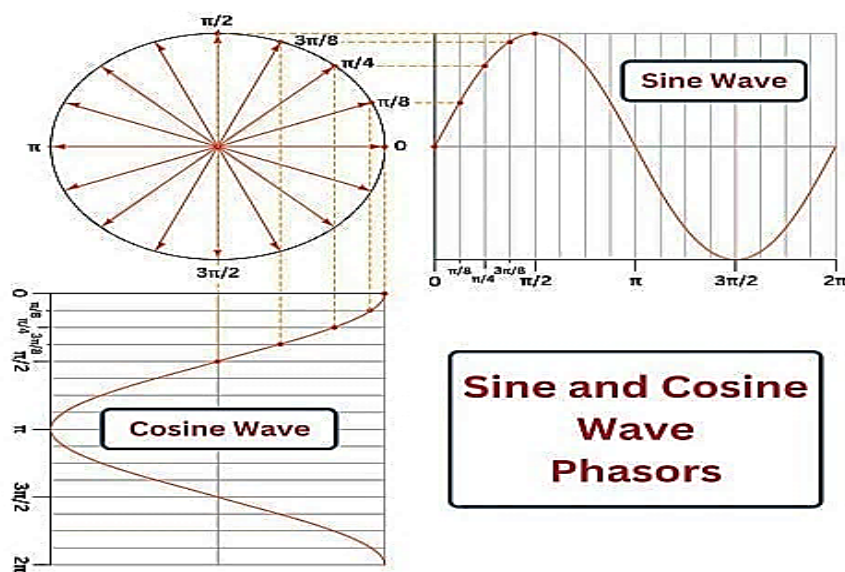

Fig. 4. Phasors diagram [52].

Overall, voltage in an AC circuit is a complex and dynamic concept that plays a crucial role in the functioning of electrical systems. Understanding the voltage behaviour in an AC circuit is essential for designing and analyzing electrical circuits and ensuring electrical devices' efficient and safe operation.

## 18 | Step-By-Step Description of the Design Procedure of an AC Circuit

Designing an AC circuit involves a systematic process that requires careful consideration of various factors to ensure optimal performance and efficiency. This section will provide a step-by-step explanation and description of the design procedure for an AC circuit. The steps are:

- I. The first step in designing an AC circuit is determining its requirements and specifications. This includes identifying the voltage and current ratings, frequency, power factor, and other relevant parameters. It is essential to clearly understand the desired performance characteristics of the circuit before proceeding with the design [53].
- II. Once the requirements are established, the next step is to select the appropriate components for the circuit. This includes choosing the right type of resistors, capacitors, inductors, and other components based on the specifications of the circuit. It is crucial to consider factors such as component ratings, tolerances, and compatibility to ensure the circuit operates as intended.
- III. After selecting the components, the next step is calculating the components' values based on the circuit's desired performance characteristics. This involves using mathematical formulas and equations to determine the values of resistors, capacitors, and inductors that meet the circuit requirements. It is essential to perform thorough calculations to ensure the circuit functions properly and efficiently.
- IV. Once the component values are calculated, the next step is to create a schematic diagram of the circuit. This involves drawing a detailed diagram showing the connections between the components and the current flow in the circuit. The schematic diagram serves as a visual representation of the circuit design and helps ensure all connections are correct and properly configured.
- V. After creating the schematic diagram, the next step is to build a circuit prototype. This involves assembling the components on a breadboard or PCB and testing the circuit to ensure it functions as intended. It is

important to carefully test the circuit and make necessary adjustments to meet the specifications and requirements.

- VI. Once the prototype is successfully tested, the final step is to finalize the design and create detailed circuit documentation. This includes creating a bill of materials, a parts list, and a detailed circuit design description. It is essential to document the design process thoroughly to ensure that the circuit can be replicated and maintained in the future.

Designing an AC circuit requires a systematic and thorough approach to ensure optimal performance and efficiency. By following the step-by-step procedure outlined in this paper, designers can create a well-designed and functional AC circuit that meets the requirements and specifications of the application.

## 19 | Power Dissipation in an AC Circuit

Power dissipation in an AC circuit is a crucial concept in electrical engineering that refers to converting electrical energy into heat within the circuit components. This phenomenon occurs due to the resistance of the components to the flow of AC, leading to the generation of heat as a byproduct [54]. Understanding power dissipation is essential for designing and analyzing AC circuits to ensure efficient operation and prevent overheating of components. The following are the critical functions of power dissipation in an AC circuit.

- I. In an AC circuit, power dissipation is primarily caused by the resistance of the circuit elements, such as resistors, wires, and other components. When an AC flows through a resistor, the material's resistance causes collisions between electrons and atoms, converting electrical energy into heat [55]. This heat generation is proportional to the square of the current flowing through the resistor and the component's resistance, as described by the formula  $P = I^2R$ , where  $P$  is the power dissipated,  $I$  is the current, and  $R$  is the resistance.
- II. Power dissipation is crucial for determining the efficiency of an AC circuit and ensuring that the components can handle the heat generated during operation. Excessive power dissipation can lead to overheating of components, which can cause damage or even circuit failure. Therefore, engineers must carefully calculate and manage power dissipation in AC circuits to prevent such issues [56].

Power dissipation in an AC circuit is a fundamental concept in electrical engineering that describes the conversion of electrical energy into heat due to the resistance of circuit components.

## 20 | Heat Generation in an AC Circuit

Heat generation in an AC circuit is expected due to the current flow. Heat generation in an AC Circuit is produced through:

- I. When an AC flows through a circuit, it encounters resistance from the wires, components, and other elements. This resistance causes the electrons in the current to collide with atoms in the material, converting electrical energy into heat energy [57].
- II. The amount of heat generated in an AC circuit can be calculated using the formula  $P = I^2R$ , where  $P$  is the power dissipated as heat,  $I$  is the current flowing through the circuit, and  $R$  is the resistance of the circuit. This formula shows that the heat generated is proportional to the current's square and the circuit's resistance. Therefore, increasing the current or the resistance will generate more heat [58].
- III. Excessive heat can lead to overheating, component failure, and fire hazards. To prevent these issues, engineers and designers must carefully consider the heat dissipation capabilities of the components used in the circuit, as well as the overall design of the system. This may involve using heat sinks, fans, or other cooling mechanisms to dissipate the heat generated by the circuit [59].

Heat generation in an AC circuit is a natural consequence of current flow through a resistive medium. Understanding the factors contributing to heat generation, such as current and resistance, is essential for designing safe and efficient electrical systems. By taking appropriate measures to manage heat generation, engineers can ensure the reliability and longevity of AC circuits.

## 21 | Impact of Overheating in AC Circuit

Overheating in an AC circuit can significantly impact the system's performance and longevity. An AC circuit overheats can lead to various issues, including reduced efficiency, increased energy consumption, and potential component damage [60]. Some of the primary impacts of overheating in an AC circuit are outlined below:

- I. **Reduced efficiency:** when components in the circuit become too hot, they may not function as effectively, leading to a decrease in the system's overall efficiency. This can result in higher energy bills as the system has to work harder to maintain the desired temperature.
- II. **Overheating can also cause the system to run less smoothly,** leading to increased wear and tear on components and potentially shortening the system's lifespan.
- III. **Potential for damage to components:** when components become too hot, they can damage or even fail. This can result in costly repairs or replacements and downtime for the system. Overheating can even pose a fire hazard in extreme cases, putting the system and the building at risk.

Overheating in an AC circuit can have a range of negative impacts on the system, including reduced efficiency, increased energy consumption, and potential damage to components. Proper maintenance and monitoring are essential to prevent overheating and ensure the long-term performance of an AC circuit [61]. Taking proactive steps to address overheating issues makes maintaining a safe and efficient AC system possible.

## 22 | Prevention Measures of Overheating in AC Circuits

Overheating in AC circuits is a common issue that can lead to equipment failure, downtime, and even safety hazards. Businesses and individuals must implement preventive measures to ensure the proper functioning of their AC circuits. Some of the most critical prevention measures are:

- I. **Ensure proper ventilation and airflow around the AC circuits:** overheating can occur when the circuits are enclosed in a tight space with limited airflow. By providing adequate ventilation, heat can dissipate more effectively, reducing the risk of overheating [57].
- II. **Regularly inspect and maintain the AC circuits:** loose connections, damaged components, and dust buildup can all contribute to overheating. By conducting routine inspections and maintenance, potential issues can be identified and addressed before they escalate into major problems.
- III. **Monitor the temperature of the AC circuits regularly:** installing temperature sensors and alarms can help alert users to any abnormal increases in temperature, allowing them to take prompt action to prevent overheating [62].
- IV. **Use high-quality components and materials to construct AC circuits:** this can also help prevent overheating. Inferior components may be unable to handle the heat generated by the circuits, leading to overheating and potential failure. Investing in quality components can help ensure the reliability and longevity of the AC circuits.

Overheating in AC circuits can have serious consequences, but by implementing preventive measures such as ensuring proper ventilation, conducting regular maintenance, monitoring temperature, and using high-quality components, the risk of overheating can be significantly reduced [63]. Businesses and individuals need to prioritize the prevention of overheating in AC circuits to ensure the efficient and safe operation of their equipment.

## 23 | Different Components in an AC Circuit

An AC circuit consists of various components that work together to facilitate the flow of electrical energy. These components play crucial roles in ensuring the efficiency and functionality of the circuit. This section will enlist in detail the different components of an AC circuit.

- I. The voltage source provides the electrical energy needed to power the circuit. The voltage source can be either a battery or a generator, which is responsible for creating the potential difference that drives the current flow through the circuit. Without a voltage source, an AC circuit could not function.
- II. The resistor: this is used to control the amount of current flowing through the circuit. Resistors are designed to resist the flow of electrical current, and they are used to regulate the voltage and current levels in the circuit. By adjusting the resistance of a resistor, the amount of current flowing through the circuit can be controlled.
- III. Inductors: these are also essential components in an AC circuit, as they store and release energy in the form of a magnetic field. When an AC flows through an inductor, it creates a magnetic field that stores energy. This stored energy is then released into the circuit when the current changes direction. AC circuits commonly use inductors to filter out unwanted signals and regulate current flow.
- IV. Capacitors are another essential component in an AC circuit, as they store and release energy in an electric field. When a voltage is applied to a capacitor, it stores energy as an electric field. This stored energy is released back into the circuit when the voltage changes. AC circuits often use capacitors to smooth out voltage fluctuations and store short-term energy.

The components in an AC circuit work together to facilitate the flow of electrical energy and regulate the circuit's voltage and current levels. Each component plays a unique role in ensuring the efficiency and functionality of the circuit [64].

## 24 | Electromechanical Applications of AC Circuit

AC circuits are widely used in various applications across different industries due to their versatility and efficiency. The various applications of AC circuits and their importance in modern technology are as follows:

- I. Power distribution systems: AC power is generated at power plants and transmitted over long distances through power lines. The use of AC circuits in power distribution allows for efficient transmission of electricity over long distances with minimal loss of power. This is due to the ability of AC circuits to quickly step up or down the voltage using transformers, which helps reduce power losses during transmission [65].
- II. Electric motors: AC motors are widely used in various industrial applications, such as pumps, fans, compressors, and conveyor systems. AC motors are preferred over DC motors due to their simplicity, reliability, and cost-effectiveness. AC motors can be easily controlled using variable frequency drives, allowing for precise motor speed and torque control.
- III. Heating, Ventilation, and Air Conditioning (HVAC) systems: AC circuits power the compressors and fans in HVAC systems, essential for maintaining comfortable indoor temperatures. AC circuits in HVAC systems allow for efficient cooling and heating of buildings, resulting in energy savings and reduced operating costs [66].
- IV. In addition to power distribution, electric motors, and HVAC systems, AC circuits are used in various other applications, such as lighting, telecommunications, and electronics. AC circuits are used in lighting systems to power fluorescent and LED lights, energy-efficient alternatives to incandescent bulbs. AC circuits are also used in telecommunications systems to transmit data over long distances using fibre optic cables. In electronics, AC circuits are used in audio amplifiers, power supplies, and signal processing circuits [67].

AC circuits play a crucial role in modern technology and are essential for various applications in power distribution, electric motors, HVAC systems, lighting, telecommunications, and electronics. The versatility and efficiency of AC circuits make them indispensable in today's world, and their importance is likely to continue growing as technology advances.

## 25 | Materials Used in AC Circuits

In an AC circuit, various materials are utilized to facilitate the flow of electricity and ensure the efficient operation of electrical devices. These materials play a crucial role in the functionality and performance of the

circuit, as they determine the electrical system's conductivity, insulation, and overall effectiveness [68]. This section lists materials commonly used in an AC circuit, highlighting their properties and significance in electrical engineering.

- I. **Copper:** copper is one of the most widely used materials in AC circuits due to its high conductivity and low resistance. It is commonly used in wiring, cables, and busbars to carry electrical current efficiently and effectively. Copper's excellent conductivity allows for minimal energy loss and ensures the smooth flow of electricity in the circuit [69].
- II. **Aluminium:** aluminium is another popular material used in AC circuits, particularly high-voltage transmission lines. While not as conductive as copper, Aluminium is lightweight and cost-effective, making it a suitable alternative for long-distance power transmission [70]. Aluminium's lower conductivity is compensated by its larger cross-sectional area, allowing for the efficient transfer of electricity over long distances.
- III. **Insulators:** insulators are materials that prevent the flow of electricity and are essential for maintaining the integrity and safety of an AC circuit. Typical insulating materials include rubber, plastic, and ceramic, which coat wires, cables, and electrical components to prevent short circuits and electrical hazards. Insulators play a critical role in isolating conductive materials and ensuring the proper functioning of the circuit [71].
- IV. **Semiconductors:** semiconductors are materials with intermediate conductivity between conductors and insulators, such as silicon and germanium. In AC circuits, semiconductors are used in electronic devices like diodes and transistors to control the flow of electricity and regulate voltage levels. Semiconductors are essential for signal processing, amplification, and switching in AC circuits, making them indispensable in modern electronics [72].
- V. **Magnetic materials:** magnetic materials like iron, nickel, and cobalt are used in AC circuits for their magnetic properties, such as permeability and hysteresis. These materials are commonly found in transformers, inductors, and motors, where they help convert electrical energy into magnetic energy and vice versa. Magnetic materials play a crucial role in the operation of electromagnetic devices and are essential for power generation and distribution in AC circuits [73].

The materials listed above are essential components of an AC circuit, each serving a specific purpose in ensuring the efficient and reliable flow of electricity. From conductors like copper and Aluminium to insulators, semiconductors, and magnetic materials, each material plays a critical role in the functionality and performance of electrical systems [74]. Understanding the properties and significance of these materials is essential for designing and maintaining AC circuits that meet the demands of modern electrical engineering.

## 26 | Advantages of AC Circuits

AC circuits, or AC circuits, have numerous advantages that make them essential in various applications. Some of the critical advantages of AC circuits and why they are preferred over DC circuits in many situations are stated as follows:

- I. **Their ability to easily change voltage levels using transformers:** this allows for efficient transmission of electricity over long distances, as the voltage can be stepped up for transmission and then stepped down for use in homes and businesses. This contrasts with DC circuits, which require more complex and less efficient methods for changing voltage levels [75].
- II. **Their ability to easily control power levels using resistors, capacitors, and inductors makes AC circuits more versatile and adaptable to different applications,** as power levels can be adjusted as needed. In contrast, DC circuits have more limited options for power control, making them less flexible in certain situations [76].
- III. **AC circuits are generally safer than DC circuits** As the voltage in an AC circuit periodically reverses direction, reducing the risk of electric shock. This is why AC power is used in most homes and businesses, as it poses less danger to individuals working with electrical systems [77].



- IV. AC circuits are more efficient for powering large appliances and machinery: They can handle higher power levels without bulky and expensive components. This is why AC power is used in industrial settings, where high power requirements are standard [78].

AC circuits offer numerous advantages over DC circuits, including quickly changing voltage levels, controlling power levels, and providing a safer and more efficient power source. These advantages make AC circuits essential in a wide range of applications, from powering homes and businesses to running industrial machinery.

## 27 | Disadvantages of AC Circuits

AC circuits are widely used in electrical systems for their ability to transmit power over long distances efficiently. However, despite their advantages, AC circuits also have several disadvantages that can impact their performance and reliability—some of the demerits of AC circuits and the reasons consideration when designing electrical systems.

- I. Power losses due to resistance in the conductors: as current flows through the wires, it encounters resistance, generating heat. This heat not only wastes energy but also reduces the efficiency of the circuit. In contrast, DC circuits have lower resistance losses, making them more efficient for specific applications [79].
- II. The skin effect phenomenon: the current tends to flow more towards the conductor's surface than through its entire cross-section. This results in increased resistance and power losses, especially at high frequencies. In contrast, DC circuits do not exhibit skin effects, making them more suitable for high-frequency applications [80].
- III. AC circuits are more susceptible to Electromagnetic Interference (EMI) and Radio Frequency Interference (RFI) than DC circuits. The changing magnetic fields in AC circuits can induce unwanted currents in nearby conductors, leading to signal distortion and reduced performance. This is particularly problematic in sensitive electronic devices where signal integrity is crucial [81].
- IV. AC circuits require more complex components, such as transformers, capacitors, and inductors, to regulate voltage and current levels. These components add cost and complexity to the system, making AC circuits less attractive for specific applications where simplicity and cost-effectiveness are vital [82].

Overall, while AC circuits have many advantages, it is essential to consider their disadvantages when designing electrical systems. By understanding the limitations of AC circuits and weighing them against their benefits, engineers can make informed decisions to ensure optimal performance and reliability in their designs.

## 28 | Conclusion and Recommendations

The findings from this study on AC circuits have provided valuable insights into the behaviour and characteristics of ACs in electrical systems. It has uncovered the complex dynamics of AC circuits, including the effects of resistance, capacitance, and inductance on voltage and current. Some of the key findings from the study include the importance of impedance in AC circuits, which is a measure of the opposition to the flow of current. By understanding how impedance affects the current flow in a circuit, engineers and technicians can design more efficient and reliable electrical systems. This study has also shed light on the phenomenon of resonance in AC circuits, where the impedance of a circuit is minimized at a specific frequency. This knowledge has practical applications in the design of filters and tuning circuits for various electronic devices. The findings obtained from this study have laid the foundation for the development of modern electrical engineering principles and practices. By building upon this knowledge, researchers can continue to advance the field of AC circuit analysis and design, leading to more innovative and efficient electrical systems in the future. In light of the aforementioned views on AC circuits, the following recommendations are suggested:

- I. Proper grounding: one of the most critical recommendations based on AC circuits is to ensure proper grounding of electrical systems. Grounding helps prevent electrical shocks and ensures the safety of individuals and equipment. It also helps reduce EMI and improve the system's overall performance.
- II. Protective devices: another essential recommendation is to use protective devices such as circuit breakers, fuses, and surge protectors in AC circuits. These devices help to protect the system from overloads, short circuits, and voltage spikes, which can cause damage to equipment and pose a safety hazard.
- III. Regular maintenance: it is essential to conduct regular maintenance of AC circuits to ensure their proper functioning and longevity. This includes checking for loose connections, inspecting insulation, and testing the performance of components such as capacitors and inductors. Regular maintenance can help to prevent unexpected failures and downtime.
- IV. Proper sizing of components: this study has shown that proper sizing of components such as wires, transformers, and capacitors is crucial for the efficient operation of AC circuits. Undersized components can lead to overheating and voltage drops, while oversized components can incur unnecessary costs and inefficiencies. It is important to carefully calculate components' required ratings and capacities based on the system's specific requirements.
- V. Consideration of harmonics: this study has also highlighted the importance of harmonics in AC circuits. Harmonics are unwanted frequencies that can distort the waveform of the AC signal and cause issues such as overheating, equipment malfunctions, and power quality problems. It is crucial to design AC circuits with proper filtering and mitigation techniques to reduce the impact of harmonics.

By following these recommendations, engineers and technicians can design, install, and maintain AC circuits that meet the required standard of performance and reliability, ensuring the safe and efficient operation of electrical systems. Proper grounding, use of protective devices, regular maintenance, proper sizing of components and consideration of harmonics are vital factors when working with AC circuits. By implementing these recommendations, AC technology's continued success and advancement in various applications can be ensured.

## Conflict of Interest

There are no Conflict of Interest to declare concerning the content of this manuscript

## Funding

this does not apply to this manuscript

## Author Contributions

Kufre Rechar Ekanem contributed to the conceptualization, methodology design, and overall direction of the study. He also took the lead in writing the manuscript.

Imoh Ime Ekanem was responsible for data analysis, interpretation of results, and assisted with manuscript revisions.

Aniekan Essienubong Ikpe contributed to the literature review, prepared the figures and tables, and supported the editing and proofreading of the manuscript. All authors discussed the results and contributed to the final manuscript.

## References

- [1] Arfken, G. (1984). *International edition university physics*. Elsevier. DOI:10.1016/b978-0-120-59858-8.x5001-8
- [2] Rahmani-Andebili, M. (2021). *AC electrical circuit analysis*. Switzerland: Springer International. DOI: 10.1007/978-3-030-60986-3

- [3] Pacuku, E. (2016). Design, maintain, test batteries in mission critical facilities: engineering design, maintenance, and testing of batteries in mission critical facilities is imperative for proper operation and safety. *Consulting specifying engineer*, 53(11), DE1--DE1.
- [4] Kezunovic, M. (2005). Fundamentals of power system protection. In *The electrical engineering handbook* (pp. 787–803). Elsevier. DOI: 10.1016/B978-012170960-0/50058-X
- [5] Vaillancourt, K., Simbolotti, G., & Tosato, G. (2014). Electricity transmission and distribution. *IEA etsap-technology briefe*, 12, 2014.
- [6] Matejic, S. (2015). *The essential Nikola Tesla, peacebuilding endeavour*. Tesla Memory Project, UNESCO Center for Peace, TESLIANUM Energy Innovation Center. [https://prljevic.com/wp-content/uploads/2020/07/The-essential-Nikola-Tesla\\_prezentacija-publikacije\\_Harvard.pdf](https://prljevic.com/wp-content/uploads/2020/07/The-essential-Nikola-Tesla_prezentacija-publikacije_Harvard.pdf)
- [7] Allerhand, A. (2017). A contrarian history of early electric power distribution [scanning our past]. *Proceedings of the IEEE*, 105(4), 768–778. DOI:10.1109/JPROC.2017.2677558
- [8] Rakesh, S. (2015). *Power electronics digital notes*. Mallareddycollege of Engineering and Technology, (Autonomous Institution – UGC, Govt. of India). <https://www.slideshare.net/slideshow/power-electronics-digital-notespdf/255429986>
- [9] Oyedepo, S. O. (2012). Energy and sustainable development in Nigeria: the way forward. *Energy, sustainability and society*, 2(15), 1–17. DOI:10.1186/2192-0567-2-15
- [10] Strielkowski, W., Civiń, L., Tarkhanova, E., Tvaronavičienė, M., & Petrenko, Y. (2021). Renewable energy in the sustainable development of electrical power sector: a review. *Energies*, 14(24), 8240. DOI:10.3390/en14248240
- [11] Ang, T. Z., Salem, M., Kamarol, M., Das, H. S., Nazari, M. A., & Prabakaran, N. (2022). A comprehensive study of renewable energy sources: classifications, challenges and suggestions. *Energy strategy reviews*, 43, 100939. DOI:10.1016/j.esr.2022.100939
- [12] White, J. K. (2024). *The truth about energy: our fossil-fuel addiction and the transition to renewables*. Cambridge University Press.
- [13] Kabeyi, M. J. B., & Olanrewaju, O. A. (2023). Smart grid technologies and application in the sustainable energy transition: a review. *International journal of sustainable energy*, 42(1), 685–758. DOI:10.1080/14786451.2023.2222298
- [14] Pollard, J. (2024). *The history of power electronics: from tesla to today*. <https://www.electropages.com/blog/2024/03/the-history-of-power-electronics>
- [15] Coltman, J. W. (1988). The transformer. *Scientific american*, 258(1), 86–95. <https://www.jstor.org/stable/24988950>
- [16] Skjong, E., Rødskar, E., Molinas, M., Johansen, T. A., & Cunningham, J. (2015). The marine vessel's electrical power system: from its birth to present day. *Proceedings of the IEEE*, 103(12), 2410–2424. DOI:10.1109/JPROC.2015.2496722
- [17] Rafin, S. M. S. H., Ahmed, R., Haque, M. A., Hossain, M. K., Haque, M. A., & Mohammed, O. A. (2023). Power electronics revolutionized: a comprehensive analysis of emerging wide and ultrawide bandgap devices. *Micromachines*, 14(11), 2045. DOI:10.3390/mi14112045
- [18] Zhang, G., Li, Z., Zhang, B., & Halang, W. A. (2018). Power electronics converters: past, present and future. *Renewable and sustainable energy reviews*, 81, 2028–2044. <https://doi.org/10.1016/j.rser.2017.05.290>
- [19] Mansouri, A., Magri, A. El, Lajouad, R., Myasse, I. El, Younes, E. K., & Giri, F. (2023). Wind energy based conversion topologies and maximum power point tracking: a comprehensive review and analysis. *E-prime - advances in electrical engineering, electronics and energy*, 6, 100351. DOI:10.1016/j.prime.2023.100351
- [20] Dini, P., Saponara, S., & Colicelli, A. (2023). Overview on battery charging systems for electric vehicles. *Electronics*, 12(20), 4295. <https://doi.org/10.3390/electronics12204295>
- [21] Nasser, A. M., Refky, A., Shatla, H., & Abdel-hamed, A. M. (2024). A grey wolf optimization-based modified SPWM control scheme for a three-phase half bridge cascaded multilevel inverter. *Scientific reports*, 14(1), 7016. DOI:10.1038/s41598-024-57262-0
- [22] Abri, D. Al, Malik, A. S., Al-Saadi, S., Albadi, M., Charabi, Y., & Hosseinzadeh, N. (2022). Smart grids and smart buildings. In *Handbook of climate change mitigation and adaptation: third edition* (Vol. 4, pp. 2215–2270). Springer. DOI: 10.1007/978-3-030-72579-2\_78

- [23] Saianiruth, M., Vinothkumar, K., & Karthik, P. (2017). *Smart grid technology and its impact on renewable energy integration*. 10.13140/RG.2.2.25508.14722
- [24] Jemei, S., & Pahon, E. (2023). Encyclopedia of electrical and electronic power engineering. *Control of fuel cell systems*, 3, 472–484. <https://hal.science/hal-04153978/>
- [25] Griffiths, A. D., Herrnsdorf, J., McKendry, J. J. D., Strain, M. J., & Dawson, M. D. (2020). Gallium nitride micro-light-emitting diode structured light sources for multi-modal optical wireless communications systems. *Philosophical transactions of the royal society a: mathematical, physical and engineering sciences*, 378(2169), 20190185. DOI:10.1098/rsta.2019.0185
- [26] Stanciu, L., & Diaz-Amaya, S. (2021). *Introductory biomaterials: an overview of key concepts*. Academic Press. <https://www.amazon.com/Introductory-Biomaterials-Overview-Biomedical-Engineering/dp/0128092637>
- [27] Johnson, D. E., Hilburn, J. L., Johnson, J. R., Scott, P. D., & Education, M. H. (1997). *Electric circuit analysis*. Wiley. <https://www.amazon.com/Electric-Circuit-Analysis-David-Johnson/dp/0471365718>
- [28] Putz, L., Bednarek, K., & Nawrowski, R. (2019). Disturbances generated by lighting systems with LED lamps and the reduction in their impacts. *Applied sciences (Switzerland)*, 9(22), 4894. DOI:10.3390/app9224894
- [29] Srivastava, A., Srivastava, P., Bajpai, S. K. and Srivastava, J. K. (2023). *Electrical engineering concepts and fundamentals*. San International Scientific Publication. <https://doi.org/10.59646/electengcon/084>
- [30] Wadie, F., Elsis, M., & Eliyan, T. (2024). New multi-injection commutation topology for circuit breakers of HVDC transmission lines. *Scientific reports*, 14(1), 3468. DOI:10.1038/s41598-024-53832-4
- [31] Bird, J. (2017). *Electrical circuit theory and technology*. Routledge. <https://doi.org/10.4324/9781315561929>
- [32] Fish, R. M., & Geddes, L. A. (2009). Conduction of electrical current to and through the human body: a review. *Eplasty*, 9, e44. <https://www.ncbi.nlm.nih.gov/pmc/articles/PMC2763825/>
- [33] Lazanas, A. C., & Prodromidis, M. I. (2023). Electrochemical impedance spectroscopy— a tutorial. *ACS measurement science au*, 3(3), 162–193.
- [34] Zaidi, M. N., & Ali, A. (2018). Power factor improvement using automatic power factor compensation (APFC) device for medical industries in malaysia. *MATEC web of conferences* (Vol. 150, p. 1004). EDP Sciences. DOI: 10.1051/mateconf/201815001004
- [35] Dryden, I. G. C. (2013). *The efficient use of energy*. Butterworth-Heinemann.
- [36] D'zafi'c, I., Halilovi'c, E. (2013). *Introduction to power system analysis*. International University of Sarajevo. [https://www.researchgate.net/publication/331928468\\_Introduction\\_to\\_Power\\_System\\_Analysis](https://www.researchgate.net/publication/331928468_Introduction_to_Power_System_Analysis)
- [37] Yepes, A. G., Lopez, O., Gonzalez-Prieto, I., Duran, M. J., & Doval-Gandoy, J. (2022). A comprehensive survey on fault tolerance in multiphase AC drives, part 1: general overview considering multiple fault types. *Machines*, 10(3), 208. DOI:10.3390/machines10030208
- [38] Nabidoust, F. and Nabidoust, M. (2024). AC and DC Power supply simulink in MATLAB. *European commercial social networking site for scientists and researchers*, 1. [https://www.researchgate.net/publication/377415899\\_AC\\_And\\_DC\\_Power\\_Supply\\_Simulink\\_in\\_MATLAB\\_C](https://www.researchgate.net/publication/377415899_AC_And_DC_Power_Supply_Simulink_in_MATLAB_C)
- [39] Shariff, S. M. (2024). Single-phase robust charger with high power quality for electric vehicle application. *European journal of electrical engineering and computer science*, 8(2), 50–70. DOI:10.24018/ejece.2024.8.2.576
- [40] Wahab, K., Rahal, M., & Achkar, R. (2021). Economic Improvement of power factor correction: a case study. *Journal of power and energy engineering*, 09(06), 1–11. DOI:10.4236/jpee.2021.96001
- [41] Rawlins, C. (2000). *Basic AC Circuits*. Newnes.
- [42] Bera, T. K. (2018). Bioelectrical impedance and the frequency dependent current conduction through biological tissues: a short review. *IOP conference series: materials science and engineering* (Vol. 331, p. 12005). IOP Publishing. DOI: 10.1088/1757-899X/331/1/012005
- [43] Herrera Hernández, H., M. Ruiz Reynoso, A., C. Trinidad González, J., O. González Morán, C., G. Miranda Hernández, J., Mandujano Ruiz, A., ... & Orozco Cruz, R. (2020). Electrochemical impedance spectroscopy (EIS): a review study of basic aspects of the corrosion mechanism applied to steels. *Electrochemical impedance spectroscopy*, 137–144. DOI:10.5772/intechopen.94470
- [44] Zhu, Q., & Su, Y. (2024). A non-inductive coil design used to provide high-frequency and large currents. *Sensors*, 24(7), 2027. DOI:10.3390/s24072027

- [45] Bukar, Y., Sanda, M. U., Grema, M. B. and Kolo, B. S. (2021). Evaluation of the probable use of neem oil in capacitors and determination of dielectric constant. *International journal of information, engineering and technology*, 11(4), 67–70. <https://www.arcnjournals.org/images/GARC-IJiet-2021-11-4-10.pdf>
- [46] Zekry, A. (2013). Does the current flow through a capacitor, and if so, why? [https://www.researchgate.net/post/Does\\_the\\_current\\_flow\\_through\\_a\\_capacitor\\_and\\_if\\_so\\_why/5125fa38e4f076946500000b/citation/download](https://www.researchgate.net/post/Does_the_current_flow_through_a_capacitor_and_if_so_why/5125fa38e4f076946500000b/citation/download)
- [47] Carter, A. (2011). *How capacitors behave in AC circuits*. Electrical Electronics Web. <https://www.eeweb.com/how-capacitors-behave-in-ac-circuits/>
- [48] Kamatchi, S. (n.d.). *EC8453-linear integrated circuits*. Jeppiaar Institute Of Technology. <https://www.jeppiaarinstitute.org/pdf/lectures/26.pdf>
- [49] Anthony, I. O. & Roland, U. (2017). *Introduction to electrical engineering*. Odus Press. [https://www.researchgate.net/publication/319205259\\_INTRODUCTION\\_TO\\_ELECTRICAL\\_ENGINEERING](https://www.researchgate.net/publication/319205259_INTRODUCTION_TO_ELECTRICAL_ENGINEERING)
- [50] Adapa, R., Nilsson, S. L., Andersen, B. R., & Yang, Y. (2020). Technical description of the unified power flow controller (UPFC) and its potential variations. In *Flexible ac transmission systems: facts* (pp. 299–351). Springer. [https://doi.org/10.1007/978-3-030-35386-5\\_10](https://doi.org/10.1007/978-3-030-35386-5_10)
- [51] Hindmarsh, J., & Renfrew, A. (1996). *Electrical machines and drives*. Elsevier.
- [52] Vertigan, G. (2017). *AC Circuits and Power Systems in Practice*. John Wiley & Sons.
- [53] McDonald, A., & Carroll, J. (2016). Design of generators for offshore wind turbines. In *Offshore wind farms* (pp. 159–192). Elsevier. <https://doi.org/10.1016/B978-0-08-100779-2.00008-8>
- [54] Mörée, G., & Leijon, M. (2024). Simplified current-equivalent circuit models of synchronous reluctance machines and salient pole synchronous machines considering the reluctance torque. *Energies*, 17(5), 1015. DOI:10.3390/en17051015
- [55] Eismín, T. K. (2019). *Aircraft Electricity and Electronics*. McGraw Hill. <https://www.amazon.com/Aircraft-Electricity-Electronics-Seventh-Thomas/dp/126010821X>
- [56] Schumacher, B., Bach, H. G., Spitzer, P., & Obrzut, J. (2006). Electrical properties. In *Springer handbook of materials measurement methods* (pp. 431–484). DOI: 10.1007/978-3-540-30300-8\_9
- [57] Osmani, K., Haddad, A., Lemenand, T., Castanier, B., Alkhedher, M., & Ramadan, M. (2023). A critical review of PV systems' faults with the relevant detection methods. *Energy nexus*, 12, 100257. DOI:10.1016/j.nexus.2023.100257
- [58] Petrenko, V. F., Sullivan, C. R., & Kozlyuk, V. (2011). Variable-resistance conductors (VRC) for power-line de-icing. *Cold regions science and technology*, 65(1), 23–28.
- [59] Shaikh, S., Kumar, D., Hakeem, A., & Soomar, A. M. (2022). Protection system design of induction motor for industries. *Modelling and simulation in engineering*, 2022(1), 7423018. DOI:10.1155/2022/7423018
- [60] İnci, M., Çelik, Ö., Lashab, A., Bayındır, K. Ç., Vasquez, J. C., & Guerrero, J. M. (2024). Power system integration of electric vehicles: a review on impacts and contributions to the smart grid. *Applied sciences (Switzerland)*, 14(6), 2246. DOI:10.3390/app14062246
- [61] Milsom, E. (2014). Solid wall heat losses and the potential for energy saving. *Bre*, 44(0), 136. [https://assets.publishing.service.gov.uk/media/5c409bd6ed915d389d28176f/WP2\\_Nature\\_of\\_solid\\_walls\\_in-situ\\_v3.2b.pdf](https://assets.publishing.service.gov.uk/media/5c409bd6ed915d389d28176f/WP2_Nature_of_solid_walls_in-situ_v3.2b.pdf)
- [62] Li, B., Li, Z., & Wei, L. (2017). The design of remote temperature monitoring system. *AIP conference proceedings* (Vol. 1864). AIP Publishing. <https://doi.org/10.1063/1.4992939>
- [63] Hassan, I. U., Panduru, K., & Walsh, J. (2024). An in-depth study of vibration sensors for condition monitoring. *Sensors*, 24(3), 740. DOI:10.3390/s24030740
- [64] Mayergoyz, I. D., & Lawson, W. (2012). *Basic electric circuit theory: a one-semester text*. Gulf Professional Publishing. DOI: 10.1016/C2009-1-28545-5
- [65] Albert, J. R., & Stonier, A. A. (2020). Design and development of symmetrical super-lift DC-AC converter using firefly algorithm for solar-photovoltaic applications. *IET circuits, devices and systems*, 14(3), 261–269. DOI:10.1049/iet-cds.2018.5292
- [66] Faranda, R., Hafezi, H., Akkala, K., & Lazzaroni, M. (2020). AC “back to back” switching device in industrial application. *Energies*, 13(14), 3539. DOI:10.3390/en13143539

- [67] Choetchai, P., & Thanachayanont, A. (2016). A self-starting AC-to-DC step-up converter for energy harvesting applications. *Procedia computer science*, 86, 144–147. DOI:10.1016/j.procs.2016.05.036
- [68] Dobkin, B., & Williams, J. (2011). *Analog circuit design: a tutorial guide to applications and solutions*. Elsevier.
- [69] Mousavi, S. Z., & Pourabdoli, M. (2022). Silver-coated copper particles as a new raw material for manufacturing electrical contacts. *Microelectronics reliability*, 134, 114554. <https://doi.org/10.1016/j.microrel.2022.114554>
- [70] Kgoete, F. M., Uyor, U. O., Popoola, A. P., & Popoola, O. (2024). Insight on the recent materials advances for manufacturing of high-voltage transmission conductors. *International journal of advanced manufacturing technology*, 130(9–10), 4123–4136. DOI:10.1007/s00170-023-12890-0
- [71] Akbarpour, M. R., Gazani, F., Mousa Mirabad, H., Khezri, I., Moeini, A., Sohrabi, N., & Kim, H. S. (2023). Recent advances in processing, and mechanical, thermal and electrical properties of Cu-SiC metal matrix composites prepared by powder metallurgy. *Progress in materials science*, 140, 101191. DOI:10.1016/j.pmatsci.2023.101191
- [72] Zankawi, A. A. (2015). Semiconductors, diodes, transistors and applications. *International journal of engineering and advanced technology*, 4(1), 147–155.
- [73] Mazaleyrat, F. (2020). Soft magnetic materials. In *Handbook of magnetism and magnetic materials* (pp. 1–53). Springer. [https://doi.org/10.1007/978-3-030-63101-7\\_31-1](https://doi.org/10.1007/978-3-030-63101-7_31-1)
- [74] Tian, L., Anderson, I., Riedemann, T., Russell, A., & Kim, H. (2013). Prospects for novel deformation processed Al/Ca composite conductors for overhead high voltage direct current (HVDC) power transmission. *Electric power systems research*, 105, 105–114. DOI:10.1016/j.epsr.2013.07.017
- [75] Scherz, P. (2013). *Practical electronics for inventors*. McGraw-Hill, Inc. <https://dl.acm.org/doi/abs/10.5555/1593717>
- [76] Zandabad, Y. Y., & Fazel, S. S. (2024). A single-stage variable output AC-DC converter with PFC and soft-switching for renewable energy integration. *Energy reports*, 11, 4873–4885. DOI:10.1016/j.egy.2024.04.054
- [77] Van Mulders, J., Delabie, D., Lecluyse, C., Buyle, C., Callebaut, G., Van der Perre, L., & De Strycker, L. (2022). Wireless power transfer: systems, circuits, standards, and use cases. *Sensors*, 22(15), 5573. DOI:10.3390/s22155573
- [78] Sheta, A. N., Abdulsalam, G. M., Sedhom, B. E., & Eladl, A. A. (2023). Comparative framework for AC-microgrid protection schemes: challenges, solutions, real applications, and future trends. *Protection and control of modern power systems*, 8(2), 1–40. DOI:10.1186/s41601-023-00296-9
- [79] Njema, G. G., Ouma, R. B. O., & Kibet, J. K. (2024). A review on the recent advances in battery development and energy storage technologies. *Journal of renewable energy*, 2024(1), 2329261.
- [80] Elliott, B. J. (2000). *Cable engineering for local area networks*. CRC Press. DOI: 10.1533/9781855738898
- [81] Bohne, D. (2023). *Correction to: building services and energy efficient buildings*. Springer. DOI: 10.1007/978-3-658-41273-9\_9
- [82] Salman, H. M., Pasupuleti, J., & Sabry, A. H. (2023). Review on causes of power outages and their occurrence: mitigation strategies. *Sustainability*, 15(20), 15001. DOI:10.3390/su152015001